



Indoor/Outdoor Motorcycle Cover

HARLEY-DAVIDSON®

GARAGE

The exceptional deserves to be treated exceptionally. Show your ride some TLC with cleaning and service supplies created by the only people who know and love your motorcycle as much as you — the experts at Harley-Davidson.

BODYGUARD IN A BOTTLE

Oil is the lifeblood of your engine. It not only lubricates the moving parts, but also cools, cleans and flushes away all the byproducts of combustion. It lives in an environment filled with heat, friction and toxins that are determined to break it down and shorten its useful life. And it keeps the heart of your motorcycle beating at idle or at full throttle. Harley-Davidson's complete line of lubricants are formulated specifically to keep your motorcycle running strong, mile after mile.



ENGINE OIL FAQ

What's in a bottle of oil?

- The Base Stock makes up 75-80% of a bottle of oil. Generally, if it comes from the ground, it is a Mineral Oil. And if it is made in a lab or a reactor, it is Synthetic Oil.
- The Additive Pack makes up the remaining 20-25%. These are the ingredients that make oil smarter and tailored to its application. The additives include:
 - Viscosity Modifiers – lets oil flow like 20 weight oil at start-up and 50 weight oil at operating temperatures
 - Detergents – cleans inside your engine
 - Dispersants – suspends contaminants in the oil so they can be carried to the filter
 - Buffers – neutralizes acids that form in your engine
 - Anti-oxidants – prevents sludge and oil thickening oxidation
 - Corrosion inhibitors – protects internal components from corroding
 - Anti-wear additives – provides protection against internal wear

How often should I change my motorcycle engine oil?

You should change your motorcycle engine oil and engine oil filter at the first 1,000-mile service interval and at every 5,000-mile service interval thereafter. If you ride your motorcycle hard, under dusty conditions or in cold weather, the engine oil and filter should be changed more often. You should always change your engine oil and filter prior to winter storage (or any extended storage) so that your engine oil is clean and free of contaminants during this time period.

What viscosity grade should I use in my Harley® Motorcycle?

The recommended viscosity grade for all temperature conditions is SAE 20W50 Harley-Davidson® Motor Oil. The SAE 50 H-D® Motorcycle Oil is satisfactory in ambient temperatures of 60-80°F, and the SAE 60 H-D® Motorcycle Oil in ambient temperatures above 80°F. SAE 20W50 covers the broadest range of operating temperatures.

What's the difference between synthetic and petroleum-based lubricants?

Group I, II and III petroleum-based lubricants are derived from oil pumped from the ground. Group IV and V synthetic lubricants are chemically produced in a lab. Petroleum-based lubricants inherit physical components (including contaminants) of the source crude oil in the refining process, while synthetic lubricants are custom-formulated to have desired properties for specific purposes, meaning that engineers have complete control of the lubricant from start to finish – at the molecular level.

What's better in my bike – Petroleum or Synthetic?

Petroleum lubricants have been around for a long time, and are effective at lubricating in most conditions, but mineral oil can't compete with the purity of synthetic lubricants – especially in extreme conditions. Synthetic oil does a better job reducing wear and resisting breakdown under a wider range of operating temperatures.

What does SYN3® full Synthetic Motorcycle Lubricant do for my drivetrain?

SYN3® Full Synthetic Motorcycle Lubricant offers all the benefits of Genuine Harley-Davidson® Motorcycle Oil, and:

- Offers superior wear protection at higher temperatures
- Keeps engines, transmissions and primary chaincases cleaner
- Meets the anti-wear lubricity requirements of all transmission gears
- Lubricates all primary chaincase components
- Delivers smooth, sure clutch operation
- Provides long-term protection of all internal components
- Improves seal and gasket performance
- Offers superior performance in high-output engines

What makes Harley® SYN3 better than other Synthetics for my Harley motorcycle?

- SYN3 is pure, genuine, full synthetic lubricant.
- SYN3 base stocks are synthesized materials – including Poly Alfa Olefin (PAO) and Esther, which are the most pure, highest quality synthetic base stocks available
 - SYN3 has the smartest, most robust additive package developed specifically to provide maximum performance and protection in H-D® powertrains

Beware, not all synthetics are created equal.

- Due to a legal loophole, other brands are selling Highly Refined Group III mineral oil as synthetic oil
 - Head to head, SYN3 outperforms these oils
- SYN3 is a product you can trust, from a brand you can trust. Oil is the lifeblood to your Harley-Davidson; don't take chances with anything else.

Why should I use H-D™ oil in my Harley?

- No one tests as much as we do – we test on the road, on dynos and in the laboratory
 - We accumulate millions of testing miles on our engines and drive trains, using only H-D Oil
 - We test in the harshest environments – testing is performed in the extreme heat of the desert
 - We test under the most rigorous duty cycles – accelerated durability testing helps explore the limits of our designs, in less time. This is a worst case scenario for oil
 - We run thousands of hours on dynos
 - We test in the laboratory – sampling and analyzing oil to determine its life and effectiveness during use
- H-D's additive package is the best available, it's the most robust, it was created exclusively for H-D powertrains and we are the only ones who have it.

A. SCREAMIN' EAGLE® SYN3® FULL SYNTHETIC MOTORCYCLE LUBRICANT

TESTED-CERTIFIED for use in Harley-Davidson® engine, primary chaincase and transmission applications, Screamin' Eagle® SYN3® Full Synthetic Lubricant makes changing and topping off fluids a simple, one-product process. Developed with a proprietary three synthetic basestock formula, Screamin' Eagle SYN3 Lubricant is formulated to provide for long-term protection and engine cleanliness requirements, and to provide superior high-temperature protection for high-output engines. SYN3 Lubricant is formulated to maintain the coefficient of friction for proper clutch operation and to provide the proper lubrication to the primary chain drive. In addition, SYN3 Lubricant is designed to provide the correct lubricity for the anti-wear requirements of transmission gears and for improved seal protection. This formula is approved by Harley-Davidson for use in all stages of engine life and is not detrimental to the break-in stage of engines.

Formulated for use in Harley-Davidson® Engines, Transmissions and the following Primary Chaincase applications: '71-later XL, '83-'84 XR1000, '08-'13 XR, and '84-later FX, FXR, Dyna®, Softail®, Revolution® Max equipped models, Touring and Trike models.

United States

62600005 SAE 20W50 – 1 Quart.

62600031A SAE 20W50 – 1 Gallon.

Canada

62600011 SAE 20W50 – 1 Liter.

62600030A SAE 20W50 – 4 Liter.

Europe/Latin America

62600015 SAE 20W50 – 1 Liter.

Asia/Pacific

62600021 SAE 20W50 – 1 Quart.



A. SCREAMIN' EAGLE SYN3 FULL SYNTHETIC MOTORCYCLE LUBRICANT

B. H-D® GENUINE SYN BLEND MOTORCYCLE OIL

Genuine SYN Blend Motorcycle Oil is a formulation engineered by Harley-Davidson® and factory tested for optimal performance. This oil blends premium base stocks with premium Harley-Davidson® proprietary additives for: Optimized durability. Minimal friction loss. Wide ambient operating temperature. Superior durability for engine components over a wide operating range and temperature. Supports tighter engine tolerances in colder temperatures. Formulated for optimal clutch, engine, and transmission performance. Facilitates long life of emission components, including exhaust catalysts.

Fits '21-later Revolution Max equipped models

62600099 Quart, US.

62600102 Quart, Asia Pacific.

62600101 Litre, Europe/South America.

62600100 Litre, Canada.



B. H-D® GENUINE SYN BLEND MOTORCYCLE OIL

684 GARAGE

Oil & Lube

A. HARLEY-DAVIDSON GENUINE MOTORCYCLE OIL

Harley-Davidson® Genuine Motorcycle Oil is developed and tested for use in Harley-Davidson® motorcycles. Our unique additive package helps prevent engine wear and helps keep your engine cooler, cleaner and free of sludge, varnish and corrosion.

Harley-Davidson air-cooled V-Twin motorcycles operate at higher temperatures than water-cooled engines, thus a specific high temperature additive package is necessary to protect the engine. Be assured, H-D Genuine Motorcycle Oil can be trusted in a Harley-Davidson® engine.

Available in SAE 20W50, SAE 50, and SAE 60. Refer to your Harley-Davidson owner's manual for the proper SAE grade recommendation based on the climate and temperature range you ride in.

United States

62600007 SAE 20W50 – 1 Quart.

62600038A SAE 20W50 – 1 Gallon.

62600008 SAE 50 – 1 Quart.

62600009 SAE 60 – 1 Quart.

Canada

62600013 SAE 20W50 – 1 Liter.

62600041A SAE 20W50 – 4 Liter.

62600014 SAE 50 – 1 Liter.

Europe/Latin America

62600017 SAE 20W50 – 1 Liter.

62600042A SAE 20W50 – 4 Liter.

62600018 SAE 50 – 1 Liter.

Asia/Pacific

62600023 SAE 20W50 – 1 Quart.

62600043A SAE 20W50 – 1 Gallon.

62600024 SAE 50 – 1 Quart.

62600060 SAE 60 – 1 Quart.



A. HARLEY-DAVIDSON GENUINE MOTORCYCLE OIL

B. OIL CHANGE KITS

Everything you need for a complete engine oil and filter change. Select Harley-Davidson approved Screamin' Eagle® SYN3® Synthetic Lubricant or H-D Genuine Motorcycle Oil 20W50 and choose a black or chrome SuperPremium 5-micron oil filter. Package includes Oil, Oil Filter and replacement O-Ring.

SYN3 – SAE 20W50

Fits '99-later Twin Cam and Sportster® Evolution® models (except '08-'13 XR) and can be used as an upgrade for any models that requires Oil Filter P/N 63796-77A, 63805-80A, 63812-90 or 63813-90.

62600082 4 Quarts + Chrome Oil Filter.

62600083 4 Quarts + Black Oil Filter.

Fits '17-later Milwaukee-Eight® engine equipped models.

62600085A 5 Quarts + Chrome Oil Filter.

62600084A 5 Quarts + Black Oil Filter.

Fits '21-later Revolution Max models.

62600112 4 Quarts + Black Oil Filter.

HARLEY-DAVIDSON® GENUINE SYN BLEND MOTORCYCLE OIL – 4 QUART OIL CHANGE KIT

Genuine SYN Blend Motorcycle Oil is a formulation engineered by Harley-Davidson® and factory tested for optimal performance. This oil blends premium base stocks with premium Harley-Davidson® proprietary additives.

Fits '21-later Revolution® Max equipped models.

62600111 4 Quarts + Black Oil Filter.

H-D GENUINE MOTORCYCLE OIL SAE 20W50

Fits '99-later Twin Cam and Sportster Evolution models (except '08-'13 XR) and can be used as an upgrade for any models that requires Oil Filter P/N 63796-77A, 63805-80A, 63812-90 or 63813-90.

62600087 4 Quarts + Chrome Oil Filter.

62600088 4 Quarts + Black Oil Filter.

Fits '17-later Milwaukee-Eight engine equipped models.

62600089A 5 Quarts + Chrome Oil Filter.

62600090A 5 Quarts + Black Oil Filter.



B. OIL CHANGE KITS – SYN3 – SAE 20W50 CHROME



B. OIL CHANGE KITS – SYN3 – SAE 20W50 BLACK



B. OIL CHANGE KITS – H-D GENUINE - SAE 20W50 – CHROME



B. OIL CHANGE KITS - H-D GENUINE - SAE 20W50 - BLACK

GARAGE 685

Oil & Lube

C. HEAVY SYNTHETIC GEAR OIL

TESTED-CERTIFIED for use in Harley-Davidson® transmission and primary chaincase applications. Exclusively engineered for Harley-Davidson® motorcycles, this Heavy Synthetic Gear Oil is intended for use in extreme temperature environments (desert heat or cold weather), frequent two-up riding and heavy load riding applications. This dual viscosity (SAE 80W-140), heavy weight gear and primary oil was developed with proprietary additives and pure synthetic base stock so it flows better at cold start-up than in high temperatures viscosity behaves like a 140 weight oil to provide maximum protection. Formulated to maintain the proper coefficient of friction for clutch operation and to provide superior lubrication for the primary chain drive. This Gear Oil was formulated to provide specialized lubricity for the anti-wear requirements of transmission gears across a wider temperature range than mineral based oil. This Heavy Synthetic Gear Oil is approved by Harley-Davidson for use in all stages of transmission and primary chaincase life. This is not for use in the crankcase as a motor oil.

Formulated for use in all H-D® Transmissions and the following primary chaincase applications: '71-later XL, '83-'84 XR1000, '08-'13 XR, and '84-later Big Twin models with wet-type diaphragm spring clutch. Not for use in '02-'17 VRSC™ or '15-later XG models.

62600091 For U.S. markets.

62600092 For Canada.

62600093 For Europe and Latin America markets.

62600094 For Asia/Pacific markets.



C. HEAVY SYNTHETIC GEAR OIL

D. FORMULA+ TRANSMISSION AND PRIMARY CHAINCASE LUBRICANT

Developed with a proprietary mineral basestock formula and TESTED-CERTIFIED by Harley-Davidson Motor Company, Formula+ is blended to provide lubricity for the anti-wear requirements of transmission gears. Formulated to maintain the coefficient of friction for proper clutch operation and provide adequate lubrication to the primary chain, this lubricant is approved for use in all stages of transmission and primary chaincase life. Not for use in the crankcase as a motor oil.

TESTED-CERTIFIED Extended Service intervals:

Primary Chaincase

'84-later Big Twin models with wet-type diaphragm spring clutch. Every 10,000 miles, or prior to winter or extended storage periods.

Transmission

All Big Twin models. Every 20,000 miles, or prior to winter or extended storage periods.

Primary/Transmission

'71-later XL and '83-'84 XR1000 models. Every 10,000 miles, or prior to winter or extended storage periods.

Formulated for use in Harley-Davidson Transmissions and the following Primary Chaincase applications: '71-later XL, '83-'84 XR1000, '08-'13 XR, and '84-later FX, FXR, Dyna®, Softail®, Touring and Trike models with wet type diaphragm spring clutch. Not for use in '02-later VRSC™ or '15-later XG models.

62600004 1 Quart – U.S.

62600010 1 Liter – Canada.

62600019 1 Liter – Europe.

62600033 1 Quart – Asia/Pacific.



D. FORMULA+ TRANSMISSION AND PRIMARY CHAINCASE LUBRICANT

686 GARAGE

Tune Up Kits

HARLEY-DAVIDSON® TUNE UP KITS

Do it yourself and do it right with a Harley-Davidson® Tune Up Kit for Sportster®, Twin Cam or Milwaukee-Eight® engines. Each box is packed with Genuine Motor Parts, including spark plugs, oil filter, oil and primary lube and required gaskets. Easy to buy. Easy to store on the garage shelf. A tune up was never so easy.

A. MILWAUKEE-EIGHT® SYN3™ TUNE UP KIT

Do it right with Genuine Motor Parts. Each Tune Up Kit packs everything you need for a DIY service interval in a single box that's easy to buy and easy to store.

Kit contains:

- 5 quarts Genuine SYN3® oil
- SuperPremium 5-micron oil filter
- 2 quarts Harley-Davidson® Heavy Synthetic Gear Oil
- Service gasket kit
- 4 spark plugs

Fits '17-later Milwaukee-Eight engine-equipped models.

62600123 BlackFilter.

62600128 Chrome Filter.



A. MILWAUKEE-EIGHT – SYN3™ TUNE UP KIT BLACK



A. MILWAUKEE-EIGHT – SYN3™ TUNE UP KIT CHROME



D. TWIN CAM SYN3 TUNE UP KIT – BLACK



D. TWIN CAM SYN3 TUNE UP KIT – CHROME

B. MILWAUKEE-EIGHT® 20W50/FORMULA+ TUNE UP KIT

Do it right with Genuine Motor Parts. Each Tune Up Kit packs everything you need for a DIY service interval in a single box that's easy to buy and easy to store.

Kit contains:

- 5 quarts H-D Genuine Motorcycle oil 20W50
- SuperPremium 5-micron oil filter
- 2 quarts Formula+ Transmission and Primary Chaincase Lubricant
- Service gasket kit
- 4 spark plugs

Fits '17-later Milwaukee-Eight engine-equipped models.

62600131 BlackFilter.

62600132 Chrome Filter.



B. MILWAUKEE-EIGHT – 20W50/FORMULA+ TUNE UP KIT – BLACK



B. MILWAUKEE-EIGHT – 20W50/FORMULA+ TUNE UP KIT – CHROME

C. TWIN CAM 20W50/FORMULA+ TUNE UP KIT

Do it right with Genuine Motor Parts. Each Tune Up Kit packs everything you need for a DIY service interval in a single box that's easy to buy and easy to store.

Kit contains:

- 5 quarts H-D Genuine Motorcycle oil 20W50
- SuperPremium 5-micron oil filter
- 2 quarts Formula+ Transmission and Primary Chaincase Lubricant
- Service gasket kit
- 2 spark plugs

Fits '99-'18 Twin Cam models.

62600141 BlackFilter.

62600140 Chrome Filter.



C. TWIN CAM™ 20W50/FORMULA+ TUNE UP KIT – BLACK



C. TWIN CAM™ 20W50/FORMULA+ TUNE UP KIT – CHROME



E. XL SYN3 TUNE UP KIT – BLACK



E. XL SYN3 TUNE UP KIT – CHROME



F. XL 20W50/FORMULA+ TUNE UP KIT – BLACK



F. XL 20W50/FORMULA+ TUNE UP KIT – CHROME

GARAGE 687

Tune Up Kits

D. TWIN CAM SYN3™ TUNE UP KIT

Do it right with Genuine Motor Parts. Each Tune Up Kit packs everything you need for a DIY service interval in a single box that's easy to buy and easy to store.

Kit contains:

- 5 quarts Genuine SYN3® oil
- SuperPremium 5-micron oil filter
- 2 quarts Harley-Davidson® Heavy Synthetic Gear Oil
- Service gasket kit
- 2 spark plugs

Fits '99-'18 Twin Cam models.

62600139 BlackFilter.

62600138 Chrome Filter.

E. XL SYN3 TUNE UP KIT

Do it right with Genuine Motor Parts. Each Tune Up Kit packs everything you need for a DIY service interval in a single box that's easy to buy and easy to store.

Kit contains:

- 3 quarts Genuine SYN3® oil
- SuperPremium 5-micron oil filter
- 1 quart Harley-Davidson® Heavy Synthetic Gear Oil
- Required gasket and O ring
- 2 spark plugs

Fits '04-'22 Sportster models.

62600136 BlackFilter.

62600137 Chrome Filter.

F. XL 20W50/FORMULA+ TUNE UP KIT

Do it right with Genuine Motor Parts. Each Tune Up Kit packs everything you need for a DIY service interval in a single box that's easy to buy and easy to store.

Kit contains:

- 3 quarts Harley-Davidson Genuine Motorcycle oil
- SuperPremium 5-micron oil filter
- 1 quart Formula+ Transmission and Primary Chaincase Lubricant
- Required gasket and O ring
- 2 spark plugs

Fits '04-'22 Sportster models.

62600135 BlackFilter.

62600134 Chrome Filter.

688 GARAGE

Oil Filters

A. SUPERPREMIUM5™ OIL FILTERS – 5 MICRON

Utilizing advances in synthetic media technology, the SuperPremium5™ Oil Filters are Tested-Certified to provide filtration to retain dust, soot and other solid matter with low internal pressure drop. Filter also includes internal pressure relief and anti-drain back valves.

Fits '17-later Milwaukee-Eight® equipped models only.

62700297 Chrome.

62700296 Black.

Fits '99-'17 Twin Cam and '99-later Evolution® equipped models (except '08-'13 XR) and can be used as an upgrade for any motorcycle that requires Oil Filter P/N 63796-77A, 63805-80A, 63812-90 or 63813-90.

63798-99A Chrome.

63731-99A Black.

SuperPremium10 Oil Filter – 10 Micron (not shown)

Fits '02-'17 VRSC™ models.

63793-01K Black.



A. SUPERPREMIUM5 OIL FILTERS

B. GENUINE HARLEY-DAVIDSON® OIL FILTERS

Filter features cured resin impregnated paper, which removes harmful foreign particles from the oil. End caps and thermal setting adhesive provide positive seals, preventing bypassing of contaminant-laden oil.

Fits all XB and Buell™ models.

63806-00Y Black.

Fits '15-later XG models.

62700045

Fits '91-98 Dyna® models.

63813-90 Chrome, Extra Long.

Fits late '82-'84 FLH-80 Classics, '82-'86 FXWG, FXSB, FXEF and '79-early '84 XL models.

63810-80A Black, Short.

Fits '84-later XL, '08-'13 XR, '82-'94 FXR, '84-'98 Softail® and '80-'98 FLHR, FLHT and FLT models.

63796-77A Chrome, Long.

63805-80A Black, Long.



B. GENUINE HARLEY-DAVIDSON OIL FILTERS

C. LOW PROFILE OIL DRAIN PAN

Reduce the mess and cleanup required when changing the fluids on your motorcycle. This reusable Drain Pan is designed specifically for use with Harley-Davidson® motorcycles. The low-profile design fits easily under standard height and lowered motorcycles, and slips beneath the bike even when on the side stand. The 10-quart capacity pan will capture 2 engine oil changes, or the complete drain fluids (engine oil, primary and transmission) from any H-D® Powertrain, including Milwaukee-Eight and Twin Cam motorcycle. The Drain Pan is large enough to catch the oil from the entire length of the primary, and is sized to hold and drain an inverted primary cover. The Drain Pan features a raised hardware corral, a filter drain surface and a pressure vent hole to prevent messy oil burping. The drained waste oil is sealed safely inside the pan with high-quality gasketed caps and plugs. Convenient carrying handle simplifies transport to an approved waste oil facility.

63795-10 10-Quart Capacity.



C. LOW PROFILE OIL DRAIN PAN



D. OIL FILTER WRENCH – END CAP STYLE



F. OIL CATCHER DRAIN OIL FUNNEL



H. ROAD FUNNEL



E. OIL FILTER REMOVAL WRENCH



G. PRIMARY OIL FILL FUNNEL



I. TRANSMISSION/CRANKCASE FILL FUNNEL

GARAGE 689

Oil Change Accessories

D. OIL FILTER WRENCH – END CAP STYLE

Simplify oil filter removal and installation with this convenient End Cap Style Filter Wrench. The wrench grips the filter without crushing the canister, and allows the spin-on filter to be turned with a 3/8 drive socket wrench.

14900138

Fits '21-later Revolution® Max equipped models.

94863-10

For use with H-D® spin-on oil filters (except '15-later XG, '21-later RA1250 and RA1250S models).

14900091

For use with H-D spin-on oil filters for '15-later XG models.

E. OIL FILTER REMOVAL WRENCH

This slip-resistant wrench, featuring a stainless steel band, is designed to make the removal of your oil filter much easier.

94866-00

For use with H-D® spin-on oil filters (except '15-later XG, '21-later RA1250 and RA1250S models).

F. OIL CATCHER DRAIN FUNNEL

Reduce oil drips when removing the oil filter. The Oil Catcher Funnel slips below the filter, and provides access to spin the filter off its mount. Oil is captured in the funnel, and is siphoned into a bottle or catch basin through the drain tube. Smooth orange plastic surface is easy to clean after use.

63794-10

Fits '04-later XL, '08-'13 XR, '99-'17 Dyna®, '99-'16 Touring and '09-'16 Trike models.

62700199

Fits '17-later Milwaukee-Eight® engine equipped models.

G. PRIMARY OIL FILL FUNNEL

This reusable funnel makes it easy to add oil to your primary cavity. The funnel simply snaps into the derby cover opening to permit hands-free filling on the specified models. The convenient tab allows you to place the funnel in position with one hand, and the flat cone shape makes it easy to fill a tight area with no mess or spills. Smooth orange plastic surface is easy to clean after use.

62700239

Fits '18-later FL5B and '19-later Softail® models.

63797-10

Fits '06-'17 Dyna®, '07-'18 Softail (except '18 FL5B), and '07-later Touring and Trike models.

62700015

Fits '84-'00 Evolution® 1340-equipped models, '99-'05 Dyna, '00-'06 Softail and '99-'06 Touring Twin Cam-equipped models.

H. ROAD FUNNEL

This disposable folding funnel can be taken on the road and used for those times you need to replenish your bike's fluids. The funnel fits easily into your luggage, does not take up valuable storage space and can be thrown away after use. Convenient tear-off 3-pack means you will always be prepared.

97410-10

I. TRANSMISSION/CRANKCASE FILL FUNNEL

Fill your transmission and crankcase without the mess. This funnel is shaped to fit into tight spaces, and is designed to reach even the toughest access points. The anti-burp design ensures smooth oil flow, and the smooth orange plastic surface is easy to clean after use.

63799-10A

690 GARAGE

Oil & Lube

A. H-D® FORK OIL

Refer to Owner's Manual for required type.

62600025 Type B. 16 fl oz (473 ml) Bottle.

62600098 Type D. 16 fl oz (473 ml) Bottle.

62600026 Type E. 16 fl oz (473 ml) Bottle.

B. SCREAMIN' EAGLE® PERFORMANCE FORK OIL

A heavier blended oil that provides extra damping in performance applications.

62600027 16 fl oz (473 ml) Bottle.

Also available:

H-D FORK SEAL GREASE (not shown)

Required for service of fork seals.

11300005 1 oz (28 g) Tube.

C. H-D GENUINE EXTENDED LIFE ANTIFREEZE AND COOLANT

Antifreeze is pre-diluted with deionized water to eliminate cooling system contamination. Formulated to use at full strength (do not add water), this coolant provides exceptional heat transfer properties. Protects the entire cooling system against corrosion. Formula is silicate-free, phosphate-free, nitrate-free and borate-free.

For use in VRSC, XG, and models equipped with Twin-Cooled™ engines.

26800191 1 Quart US.

26800188 1 Liter International.

D. H-D DOT 5 BRAKE FLUID

For use in all models (except '06-later VRSC™, '07-later XL, '08-later XR, '06-later Dyna® and Softail® and '05-later Touring and Trike models).

41800220 12 fl oz (355 ml) Bottle.

E. PLATINUM LABEL DOT 4 BRAKE FLUID

For use in '20-later EV '06-'17 VRSC, '15-later XG, '07-later XL, '08-later XR, '06-'17 Dyna and '06-later Softail, and '05-later Touring and Trike models.

41800770 Platinum Label Dot 4 (English, Spanish)

41800771 Platinum Label Dot 4 CAN (English, French Canadian)

41800772 Platinum Label Dot 4 APC (English, Japanese, Simplified Chinese, Thai, Bahasa, Burmese, French, Malay, Vietnamese, Korean, Traditional Chinese)

41800773 Platinum Label Dot 4 Central EU (English, German, Czech, Slovak, Hungarian, Romanian, Polish, Slovenian, Croatian).

41800774 Platinum Label Dot 4 (English, Russian)

41800822 Platinum Label Dot 4 North EU (English, Dutch, Swedish, Norwegian, Finnish, Danish, Estonian, Lithuanian)

41800823 Platinum Label Dot 4 EMEA, LA (English, Italian, French, Arabic, Spanish, Portuguese, Greek, Turkish, Hebrew, Bulgarian)



A. H-D FORK OIL



B. SCREAMIN' EAGLE PERFORMANCE FORK OIL



C. H-D GENUINE EXTENDED LIFE ANTIFREEZE AND COOLANT



D. H-D DOT 5 BRAKE FLUID



E. PLATINUM LABEL DOT 4 BRAKE FLUID



F. H-D ETHANOL GUARD FUEL STABILIZER



H. HARLEY LUBE



G. SCREAMIN' EAGLE ASSEMBLY LUBE



I. H-D SPECIAL PURPOSE GREASE



J. H-D WHEEL BEARING GREASE



K. H-D HIGH-PERFORMANCE SEALANT – GRAY

GARAGE 691

Oil & Lube

F. H-D® ETHANOL GUARD FUEL STABILIZER

Blended with corrosion inhibitors, this Fuel Stabilizer is formulated to protect fuel tanks, fuel lines, carburetors and injectors from long-term exposure to the adverse affects of ethanol-blended fuel. It fights deposits that can accumulate as a result of ethanol-produced solvents, and acts as a demulsifier to eliminate condensation in your fuel system. 4 ounces treats 10 gallons of fuel.

91600001 4 fl oz (118 ml) Bottle.

G. SCREAMIN' EAGLE® ASSEMBLY LUBE

Screamin' Eagle® Assembly Lube provides superior protection during installation or servicing of internal engine components. Formulated with a high tackifier, this lubricant clings to parts and provides excellent start-up and break-in protection. It provides excellent corrosion resistance, and it won't drip off like common oil when you set coated parts aside to work on the rest of the engine. Recommended applications: cams, gears, crankpins, piston wrist pins, oil pumps, valve guides, rocker arm and push rod tips and roller tappet wheels.

11300002 4 fl oz (118 ml) Tube.

H. HARLEY LUBE

Harley Lube is a Harley-Davidson approved general lubricant.

94968-09 .25 fl oz (7.5 ml) Tube.

I. H-D SPECIAL PURPOSE GREASE

Factory approved steering head bearing lubricant for '02-later VRSC, '15-later XG, '05-later XL and XR and '97-later Dyna®, Softail® (except Springer™), Touring and Trike models. Do not use on wheel bearings.

99857-97A 14 oz (409 g) Grease Gun Cartridge.

J. H-D WHEEL BEARING GREASE

Recommended for wheel bearings and rear swingarm bearings.

99856-92 14 oz (409 g) Grease Gun Cartridge.

K. H-D HIGH-PERFORMANCE SEALANT – GRAY

High-performance, room temperature vulcanized (RTV) silicone type liquid gasket is a low-odor, non-corrosive and non-conductive sensor-safe formula. Sealant allows high elongation when cured to absorb thermal and dynamic movement of the mating surfaces and is resistant to most chemicals and solvents. Temperature Range -76°F to 482°F (-60°C to 250°C).

99650-02 1.9 oz (54 g) Tube.

Approved for use as crankcase sealant on all Harley-Davidson powertrains.

SURFACE CARE PRODUCT MAP

CLEAN

GENERAL



93600056 US
Harley® Bike Wash Kit



94844-10 GLOBAL
Cleaning Brush Kit



93600110 GLOBAL
Bug Eater Sponge



93600133
Harley® Bike Wash Bucket
GLOBAL



94651-09 N.AMERICA
HOG® Blaster Motorcycle Dryer



93600141 INT
93600129 US
Sunwash® Bike Soap

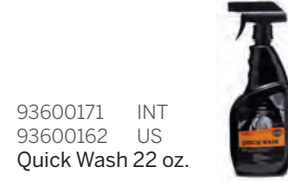

93600171 INT
93600162 US
Quick Wash 22 oz.



93600132 GLOBAL
H-D Microfiber Soft Drying Towel



93600140 INT
93600122 US
Bug Remover



93600130
Wash Mitt
GLOBAL

GLASS

93600169 INT
93600166 US
Harley-Davidson Graphene Clear Coat, 8oz



93600084 INT
93600029 US
Spray Cleaner & Polish



PAINT

93600127 INT
93600124 US
Denim Paint Cleaner



93600084 INT
93600029 US
Spray Cleaner & Polish



LEATHER, VINYL & TRIM

93600170 INT
93600167 US
Seat, Saddlebag & Trim Cleaner, 8oz. Bottle



METAL: CHROME, ALUMINUM & ENGINE

93600082 INT
93600031 US
Chrome Clean & Shine



93600084 INT
93600029 US
Spray Cleaner & Polish



WHEEL & TIRE

93600126 INT
93600121 US
Wheel & Tire Cleaner



43078-99 GLOBAL
Wheel & Spoke Brush



DETAIL

93600057A US
Harley® Detail & Protect Kit



93600125 INT
93600123 US
Gloss Detailer



93600125 INT
93600123 US
Gloss Detailer



93600156 INT
93600155 US
Scratch & Swirl Repair 8 oz.



93600081 INT
93600033 US
Black Leather Rejuvenator



93600068 INT
93600002 US
Engine Brightener



93600083 INT
93600028 US
Bare Metal Polish
(For use on bare aluminum surfaces only)



93600136 GLOBAL
Microfiber Detailing Cloth 3 pack



93600168 GLOBAL
Microfiber Applicator 4 pack



93600084 INT
93600029 US
Spray Cleaner & Polish



PROTECT

93600169 INT
93600166 US
Harley-Davidson Graphene Clear Coat, 8oz



93600169 INT
93600166 US
Harley-Davidson Graphene Clear Coat, 8oz



93600080 INT
93600034 US
Leather Protectant



93600169 INT
93600166 US
Harley-Davidson Graphene Clear Coat, 8oz
(Not for engine)



694 GARAGE

Surface Care

A. H-D™ QUICK WASH CLEANER

Fast and easy to use, Quick Wash is tough on dirt, oil and bugs, but gentle on other surfaces. Just spray it on and hose it off. Quick Wash gets into hard-to-reach spaces and cleans without scrubbing. Safe for use on all motorcycle surfaces. Does not strip wax, corrode fasteners or spokes or stain leather and vinyl seats and saddlebags. Sheeting action rinses clean and prevents spotting. Simply spray on, wait one minute and hose it off. Available in easy-to-handle trigger pump bottles and convenient refill containers.

22 fl oz Bottle.

93600162 U.S.

93600171 International.

B. SUNWASH® BIKE SOAP

This revolutionary cleaner lets riders wash their bikes where they want to – in the sun. Most bike wash products can be used only on cool days or in the shade. Has a unique formulated sheeting action that minimizes hard water spots and rinses clean even on hot days in the sun. Safe for use on all vehicle surfaces including denim paint. Biodegradable.

8 fl oz (236 ml) Bottle.

93600129 U.S.

93600141 International.

C. SPRAY CLEANER & POLISH

Keep your bike clean, even when you are away from home. Aerosol waterless quick cleaner/detailer is the perfect choice when the motorcycle is too clean to wash but too dirty to ride. Safe for use on metal, painted, plastic and windshield surfaces, this cleaning spray dissolves road grime and bugs for quick and easy cleaning and detailing. The spray floats dirt off the motorcycle, reduces static attraction to dust and leaves the surface with a great shine and UV protection.

11 oz (311 g) Aerosol Can.

93600029 U.S.

93600084 International.

D. BUG REMOVER

Remove bugs with little effort. Bugs have natural acids in their systems that can prove to be very damaging to motorcycle finishes if not removed. Melts away bugs and is safe for use on metal, painted and plastic surfaces, including Harley-Davidson® windshields. Biodegradable.

16 fl oz (473 ml) Spray Bottle.

93600122 U.S.

93600140 International.

E. WHEEL & TIRE CLEANER

The road provides plenty of nasty elements that can be potentially damaging to the finish of motorcycle wheels. Wheel & Tire Cleaner safely removes brake dust and road grime from wheels, tires and whitewalls in seconds. Also recommended for cleaning Harley-Davidson® black-coated exhaust pipes and mufflers. Biodegradable.

22 fl oz Spray Bottle.

93600121 U.S.

93600126 International.



A. QUICK WASH



F. DENIM PAINT CLEANER



G. SEAT, SADDLEBAG & TRIM CLEANER



B. SUNWASH BIKE SOAP



C. SPRAY CLEANER & POLISH



H. CHROME CLEAN & SHINE



I. GLOSS DETAILER



D. BUG REMOVER



E. WHEEL & TIRE CLEANER



J. SCRATCH & SWIRL REPAIR



K. ENGINE BRIGHTENER

GARAGE 695

Surface Care

F. DENIM PAINT CLEANER

Specially formulated for denim paint, this handy quick detailer cleans and protects the silky matte finish. Cleaner won't streak or leave residue. Just spray and gently wipe away oils, fingerprints and dust. Compatible with all surfaces on Harley-Davidson® motorcycles, this formula cleans without buffing, so you can avoid polishing the denim surface. Heavily soiled surfaces should be washed with Sunwash® Bike Soap and water before application.

16 fl oz (473 ml) Spray Bottle.

93600124 U.S.

93600127 International.

G. SEAT, SADDLEBAG, AND TRIM CLEANER

The ideal quick detailer for vinyl, leather and plastic surfaces, this one-step treatment cleans and refreshes without leaving a greasy residue. Use a microfiber applicator to apply gel directly onto the surface. Buff away the accumulated dust and grime that dulls the finish with a microfiber cloth. Ideal for use on inner fairings, dash panels, seats and saddlebags. Dries to a satin shine and contains no waxes or other solvents that can dull the surface of vinyl and plastic.

8 fl oz (236 ml) Bottle.

93600167 U.S.

93600170 International.

H. CHROME CLEAN & SHINE

Professional strength nonabrasive cleaner is formulated to ensure maximum shine on chrome-plated surfaces. The detergent-resistant formula is easy to apply and can be buffed to a bright, long-lasting finish. Can also be used to clean decorative brushed aluminum, brass and stainless steel surfaces.

4 oz (113 g) Container.

93600031 U.S.

93600082 International.

I. GLOSS DETAILER

This easy-to-apply mist produces the highest possible gloss finish in the shortest amount of time. Formulated to enhance luster and provide UV protection between waxes, this nonabrasive quick detailer can be applied to paint, clear coat, chrome, powder coat, windshields, vinyl and plastic. Gloss Detailer contains no waxes, silicones, oils or hydrocarbon solvents and will not remove Glaze™ Poly Sealant. Biodegradable.

16 fl oz (473 ml) Spray Bottle.

93600123 U.S.

93600125 International.

J. SCRATCH & SWIRL REPAIR

Formulated to remove fine scratches and swirl marks from gloss paint, this unique compound contains nonrigid abrasives that provide good initial leveling action on clear coat and become less aggressive while being buffed. This staging of grit size provides the benefits of a several-step process in one convenient bottle and leaves your clear coat with a new bike shine. Biodegradable.

8 fl oz (236 ml) Bottle.

93600155 U.S.

93600156 International.

K. ENGINE BRIGHTENER

Make your engine look new again. Engine Brightener refreshes and rejuvenates tired wrinkle black finishes on engine cases, cylinder fins, covers or anywhere else the color has faded or lost its luster. Formulated with high-temperature silicon polymer, this detergent-resistant finish restorer cleans deep into the wrinkle black surface and moisturizes the finish to return the original satin sheen. Just spray it on, let it soak in and wipe away for a fresh look.

11 oz (311 g) Aerosol Can.

93600002 U.S.

93600068 International.

696 GARAGE

Surface Care

A. H-D™ GRAPHENE SPRAY COATING

Give your motorcycle finish a new level of protection with H-D™ Graphene Spray Coating. Contains a graphene oxide component that provides a high level of long-lasting protection, reduces hard-water spotting, and keeps water from clinging to the surface. Enhances the gloss and clarity of painted and plated finishes and is easy to apply. Great for use on paint, chrome, and wheels. Not for use on brakes, tires, denim, semi-gloss or wrinkle finish surfaces. On paint creates a hard layer of scratch protection. Repels brake dust from wheels. Preserves and protects plastic surfaces. Lowers surface temperature to reduce hard water spotting embedded in clear coat. Prevents water from clinging on treated surfaces. May be applied in direct sunlight. May be applied over existing wax or polish coating.

8 fl oz (236 ml) Bottle.

93600166 U.S.

93600169 International.

B. BLACK INNER FAIRING REJUVENATOR

Great for sun-rich environments, this Inner Fairing Rejuvenator brings back the deep black color on faded Original Equipment satin-black inner fairing surfaces. Just wipe on and buff off. An occasional application restores the luxurious matte finish and provides added UV protection. Can also be used on rubber and other black plastic components.

93600115 8 fl oz (236 ml) Bottle.

C. BLACK LEATHER REJUVENATOR

Black Leather Rejuvenator puts new life back into faded black leather seats and saddlebags. To re-color and condition weathered leather, just clean the surface and apply the treatment with a Disposable Detailing Soft Cloth. Wipe off the excess, buff the leather surfaces to the desired shine, and your leather looks like new. For lasting weather protection, follow the application with H-D® Leather Protectant.

4 oz (113 g) Container.

93600033 U.S.

93600081 International.

D. LEATHER PROTECTANT

Leather Protectant offers the most effective weatherproofing and preservative action for leather saddlebags, tank panels, gear and apparel. Specially formulated for smooth, oil-tanned leather.

6 oz (170 g) Container.

93600034 U.S.

93600080 International.

E. BARE METAL POLISH

Professional strength micro-abrasive polish is formulated to remove oxidation and refurbish metal motorcycle parts that have lost their original finish. Recommended for use on polished aluminum or polished stainless steel surfaces that are not clear coated. Can also be used to polish Brass Collection components to a bright finish. Not for use on painted, chromed or plated surfaces or decorative brushed aluminum or stainless steel finishes.

4 oz (113 g) Container.

93600028 U.S.

93600083 International.

F. TIRE LETTERING PEN

Enhance your tire sidewall lettering by applying White paint. Acrylic ester resin paint provides excellent water resistance with improved color and gloss retention. Pump action paint dispensing pen allows either outlining or filling the lettering. Tip can be shaped or trimmed to allow for customized paint flow.

98625 1/3 fl oz – White.



A. H-D GRAPHENE SPRAY COATING



B. BLACK INNER FAIRING REJUVENATOR



C. BLACK LEATHER REJUVENATOR



D. LEATHER PROTECTANT



E. BARE METAL POLISH



F. TIRE LETTERING PEN



G. BIKE WASH BUCKET



H. FIREMAN-STYLE HOSE NOZZLE



I. MICROFIBER WASH MITT – ORANGE



J. WHEEL AND SPOKE BRUSH

GARAGE 697

Surface Care

G. BIKE WASH BUCKET

The perfect way to keep your bike clean, this bike wash bucket holds the key to lustrous shine. 5.0-gallon cleaning bucket features a removable Grit Guard® insert that keeps sponges and wash mitts away from the dirt particles that settle to the bottom. Use it to store cleaning products between washes.

Sturdy handle and screw-on, water-tight lid make transportation and storage a breeze.

93600133

H. FIREMAN-STYLE HOSE NOZZLE

Wash your bike in style. The unique Fireman-Style hose nozzle features a large overhand lever for convenient operation. Just adjust the lever and the nozzle maintains the pressure flow – hands free. The spray head adjusts from a steady stream to a wide fan pattern and the soft rubber nose cone protects your bike's surfaces from accidental contact. The durable metal body won't rust or corrode and the soft-touch ergonomic grip is insulated for cold-water comfort. Standard-size garden hose fitting includes gasket.

93600016

I. MICROFIBER WASH MITT – ORANGE

Premium quality microfiber mitt lifts away dirt particles from motorcycle surfaces to help prevent scratches to the finish during washing. Microfiber draws dirt from surfaces as you wash the bike. Machine washable. Custom designed to be used with either hand.

93600130

J. WHEEL AND SPOKE BRUSH

The perfect partner for Wheel & Tire Cleaner, this brush features soft, durable fibers attached to a base coated with polypropylene to prevent scratching. With a Bar & Shield logo branded into the handle, the brush has a cone shape for efficient cleaning and durable design that won't melt on hot surfaces.

43078-99

698 GARAGE

Surface Care

A. CLEANING BRUSH KIT

Make every corner of your bike shine. This set of 3 wood-handled cleaning brushes helps you reach into the tightest places. The chamois brush gently scrubs in between engine fins or can be used after rinse to soak up hard-to-reach water. The reverse spiral brush is perfect for cleaning tire sidewalls or those hard-to-reach spaces elsewhere on your bike, and the soft mop brush will leave your chrome streak free. All brushes have vinyl-coated wires to prevent scratching.

94844-10



A. CLEANING BRUSH KIT

B. BUG EATER SPONGE

Tough on bugs but gentle on other surfaces. This easy-to-grip pad features a strong, flexible core laminated with double-sided cleaning surfaces. When paired with water and Bug Remover or Wheel & Tire Cleaner sprays, the textured orange surface helps break down and dissolve baked-on bugs and road grime without scratching the surface below.

93600110



B. BUG EATER SPONGE

C. MICROFIBER APPLICATOR

Get pro detailing results faster. The flat surface of this microfiber applicator block covers more area for faster application. For use on the application of most wax, coating, sealant, and dressing products. Short pile terry microfiber fabric absorbs minimal product while applying the product evenly and smoothly. Medium-firm sponge core gently conforms to contoured motorcycle surfaces. The inside sewn edges ensure that only microfiber fabric comes in contact with paint. Pad fits right in the palm of your hand - is easy to hold and maneuver. Measures 5 x 3 x 0.75. Sold as pack of 4 applicators

93600168 4-pack.



D. MICROFIBER DETAILING CLOTH

This premium microfiber synthetic cloth is the multi-purpose choice for washing, cleaning or buffing. Highly absorbent fibers make it the best microfiber material for use on your motorcycle. Designed to help prevent scratching and allow detailing into tight corners, spaces and gaps. Edges designed not to fray after many uses. Now available in a convenient three-pack

93600136



D. MICROFIBER DETAILING CLOTH

E. MICROFIBER SOFT DRYING TOWEL

Ditch that old dishrag. This microfiber drying towel can absorb much more water than a cotton towel, enough to make short work of drying even Touring motorcycles. Washable and reusable. Provides a lint- and streak-free drying action for a professional result. Softer than cotton, this plush towel is ideal for use on any surface. Compact size is ideal for packing for morning wipe-downs on road trips

93600132



E. MICROFIBER SOFT DRYING TOWEL

F. DETAILING SWABS

Detail those hard-to-reach places. Plush cotton swabs are perfect for removing polish and wax residue from cracks and crevices, and the strong but flexible 8 shaft allows you to clean in hard to reach areas around your engine, pipes and more. Package contains 50 swabs.

93600107

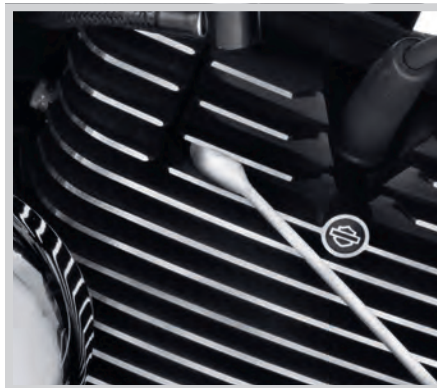

F. DETAILING SWABS



G. HARLEY BIKE WASH KIT



H. HARLEY DETAIL & PROTECT KIT

G. HARLEY® BIKE WASH KIT

Bike Wash Kit includes the essentials required to clean your bike.

- Sunwash® Bike Soap
- Bug Remover
- Wash Mitt
- Bug Eater Sponge
- Synthetic Drying Chamois
- Microfiber Detailing Cloth

93600056

H. HARLEY DETAIL & PROTECT KIT

Detail & Protect Kit includes the essentials to make your bike shine.

- Glaze™ Poly Sealant
- Gloss Detailer
- Chrome Clean & Shine
- Scratch & Swirl Repair
- Disposable Detailing Soft Cloths
- Microfiber Detailing Cloth
- Detailing Swabs

93600057A

I. SADDLEBAG STORAGE STAND

Never set your saddlebags on the ground again. This convenient folding rack holds Touring hard saddlebags while you wash or work on your bike and utilizes the bag's quarter-turn quick-disconnect fasteners to securely lock them in place. The strong, lightweight rack features 4 adjustable feet to level the stand and keep the bags off the ground. You can wash, dry, detail and re-install the bags with minimal handling. Stand accommodates both standard and extended hard saddlebags.

94778-10

Fits '95-'16 Touring models equipped with standard and extended-length saddlebags.

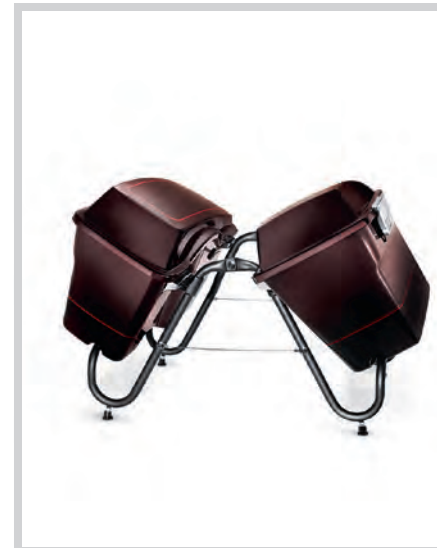

I. SADDLEBAG STORAGE STAND

J. HOG® BLASTER MOTORCYCLE DRYER

Dry your bike in minutes with the HOG® Blaster. This powerful dryer blows a stream of warm, dry, filtered air at 18,000 feet/minute, allowing you to cut your drying time up to 75%. The HOG Blaster reduces streaks and water spots because water can't hide in hard-to-reach places. No more annoying drips and runs when you move your bike. With an ergonomically friendly design for comfortable handling, the HOG Blaster features a durable all-steel outer shell, a 1.3 hp motor and a grounded electrical cord. Kit includes blower unit, flexible hose and 2 diffuser attachments. One-year manufacturer's warranty on blower unit.

94651-09 120V, Grounded 3-prong Plug. United States, Canada and Mexico.



J. HOG BLASTER MOTORCYCLE DRYER

HARLEY-DAVIDSON® MOTORCYCLE COVERS

Welcome to the best-dressed list. Unlike a tarp and bungee cords, Harley-Davidson® Motorcycle Covers fight the effects of the elements and protect your bike's paint and finishes from the rough world around us. Whether your bike spends its time in a heated garage or on the driveway, we've got you covered.

ANTENNA ACCESS
Touring and Trike covers feature hook-and-loop opening at the rear to accommodate antennas.

WATER-RESISTANT SEAMS
Heavy-duty Indoor/Outdoor covers feature taped overlapping seams for water resistance.

MOISTURE REDUCTION
Weather-shielded vents or breathable materials promote air circulation and minimize corrosion during short or long term storage.

HEAT-RESISTANT PANELS
Indoor/Outdoor and Premium Indoor Covers feature heat-resistant panels that protect the cover from warm exhaust.

REFLECTIVE TRIM
High-visibility reflective trim makes a parked and covered bike more obvious.

BELLY STRAPS
Quick-release adjustable straps cinch the cover under the frame to reduce ballooning in the wind.



CORSET-STYLE BACKBONE
Medium and large covers feature a cinching system that customizes the cover for best fit. Just pull the cord and cover adjusts to the bike's contours.

ADJUSTABLE HEM
Drawstring hem allows custom-tailored fit around the bike and eliminates the one-size-fits-some elastic cord.

LOCK ACCESS
Sewn-in grommets near the front wheel simplify the use of a cable lock or security chain (cable/lock not included).

COVER ALARM POCKET
Hidden pocket accepts optional battery-powered alarm. If the cover is disturbed, the 130-dB alarm is triggered.

	COMPACT TRAVEL	INDOOR	PREMIUM INDOOR	INDOOR/OUTDOOR	
MATERIAL	2x Polyurethane Coated Polyester	Polyester	Luxuriously Soft Microfiber	Heavy-Duty UV Resistant Diamond Pattern Polyester	
WATER-RESISTANT	✓	—	—	✓	
HEAT PANEL	—	—	✓	✓	
ANTENNA ACCESS	✓	—	✓	✓	
SECURITY FEATURES	—	Sewn-in grommets for use of front wheel chain lock & hidden internal alarm pocket			
ADJUSTABILITY	—	Corset-Style Backbone & Adjustable Hem			
REFLECTIVE TRIM	✓	✓	✓	✓	✓
INTEGRATED STORAGE POUCH	✓	✓	✓	✓	✓
BELLY STRAP	—	✓	✓	✓	✓
H-D LOGO	✓	✓	✓	✓	—
ADVENTURE TOURING	Large 93100073	—	—	ADV 93100070	—
STREET™ & SPORTSTER®	Medium 93100074	Small 93100043	—	Small 93100040	Small – Solid Black 93100041
V-ROD®, DYNA® & SOFTAIL®	Medium 93100074	Large 93100018	Medium 93100019	Medium 93100022	Medium – Solid Black 93100025
TOURING	Large 93100073	Large 93100018	Large 93100020	Large 93100023	Large – Solid Black 93100026
TRIKE	—	Large 93100018	Extra-Large 93100021	Extra-Large 93100024	Extra-Large – Solid Back 93100027

✓ Standard Feature

*NOTE: H-D® motorcycle covers are not designed to be used while trailering. Using an H-D motorcycle cover while trailering may cause the cover to tear, possibly causing damage to the cover and motorcycle.

702 GARAGE

Motorcycle Covers

A. COMPACT TRAVEL COVERS

Travel with protection. This lightweight, water-resistant Compact Travel Cover is easy to pack and covers the main motorcycle touch points from the windshield to the rear seating area. Compact and lightweight cover stores in its own pouch and requires over 40% less luggage space than a full-size motorcycle cover, so it's easy to pack along just in case. When compacted in pouch, travel cover takes up less space than a 64Oz aluminum drink container. Multiple attachment options to adjust the fit based on motorcycle model and luggage option so cover can be used on different bikes. Minimize motorcycle wipe-down after dew or light rain. Discourages tampering with the covered motorcycle for an added layer of security. Reflective logos highlight the front, rear, and sides of vehicle for added visibility when the motorcycle is parked at night offer peace of mind. Made from polyester with a water-resistant polyurethane coating.

93100073 Large.
Fits '21-later Pan America® and '14-later Touring and Tri-Glide® models. Recommended for any model with Tour-Pak® luggage installed.

93100074 Medium.
Fits '21-later RH1250S, '12-later XG, '04-later XL models, and '18-later Softail models. Not recommended for any model with Tour-Pak® luggage installed.

B. INDOOR/OUTDOOR MOTORCYCLE COVER*

Weather-shielded vents in the top of the cover promote air circulation to reduce moisture build-up and minimize corrosion. Internal heat-resistant panels protect the cover from warm exhaust and an integrated storage pouch permits convenient packing. The cover skirt features front and rear adjustable drawstrings to cinch the cover and a belly strap. Cover features a convenient opening near the front wheel for a security chain or cable and internal pockets that accept the optional Cover Alarm (P/N 69000038). The cover features reflective piping for added visibility. Fits any .875 to 1.25 diameter tubing.

Medium. Fits VRSC™, Dyna® and Softail® models.

93100022 H-D Orange/Black.

93100025 Black.

Large. Fits Touring and Freewheeler® models. Does not fit FLHXXX, FLTRT or FLHTCUTG models.

93100023 H-D Orange/Black.

93100026 Black.

Extra Large. Fits Trike models.

93100024 H-D Orange/Black.

93100027 Black.

C. PREMIUM INDOOR MOTORCYCLE COVER*

Promotes air circulation to reduce moisture build-up and minimize corrosion. The cover's skirt features front and rear adjustable drawstrings to cinch the cover and a belly strap. The cover features heat-resistant panels that protect the material from warm exhaust. Cover features a convenient opening near the front wheel for a security chain or cable and internal pockets that accept the optional Cover Alarm (P/N 69000038).

Small. Fits XG, XL and XR models.

93100042 H-D Orange/Black.

Medium. Fits VRSC, Dyna and Softail models.

93100019 H-D Orange/Black.

Large. Fits Touring and Freewheeler models. Does not fit FLHXXX, FLTRT or FLHTCUTG models.

93100020 H-D Orange/Black.

Extra large. Fits Trike models.

93100021 H-D Orange/Black.

D. INDOOR MOTORCYCLE COVER*

This breathable polyester cover promotes air circulation to reduce moisture build-up and minimize corrosion. The cover's skirt features front and rear adjustable drawstrings to cinch the cover around the bike and a convenient belly strap. The cover features a convenient opening near the front wheel for a security chain or cable and internal pockets that accept the optional Cover Alarm (P/N 69000038).

Small. Fits XG, XL and XR models.

93100043 H-D Orange/Black.

Large. Fits Touring, Freewheeler and RH models.

93100018 H-D Orange/Black.



*NOTE: H-D® motorcycle covers are not designed to be used while trailering. Using an H-D motorcycle cover while trailering may cause the cover to tear, possibly causing damage to the cover and motorcycle.



***WARNING:** Do not use while riding; could result in death or serious injury.

MOTORCYCLE COVERS

GARAGE 703

Motorcycle Covers & Storage Accessories

E. OASIS DAY COVER*

Keep your seat dry when you stop for the night. Lightweight and compact for travel, this easy-to-store cover rolls into the built-in bag. Made from soft micro-fiber, the black and orange water repellent fabric dries quickly for a quick getaway. Hook-and-loop closures in the rear let you slip the cover over your antennas and the elastic bottom hem and footboard stirrups ensure a snug fit. The Harley-Davidson script and Bar & Shield logos prominently stand out on the fabric.

93100028 H-D Orange/Black.
Fits Touring and Trike models equipped with Tour-Pak® luggage.



E. OASIS DAY COVER

F. MOTORCYCLE COVER ALARM

Protect your covered motorcycle from tampering. Self-contained alarm fits into the pocket on select H-D® Motorcycle Covers. The snap swivel clips to spokes, rotors or other fixed parts and the cord leads back to the alarm pin. If the cover is pulled off the bike, the pin is pulled, triggering the 130-dB alarm. Weatherproof alarm is powered by a replaceable 9V battery (not included).

69000038
Fits select H-D Motorcycle Covers with alarm pocket.



F. MOTORCYCLE COVER ALARM

G. RAIN COVERS*

Featuring a handy storage sack, this black nylon, water-resistant, Cordura® cover packs easily and shelters your seat from the storm.

51638-97 Solo Seat.
Fits H-D® solo seats (except XR and FLSTS).

51639-97 Two-Up Seat.
Fits VRSC™, XG, XL, Dyna® and Softail® models with Two-Up Seats. Does not fit Touring and Trike models. Does not fit with Rider Backrests.

52952-97 Seat with Rider Backrest.
Fits H-D Touring and Trike seats. Fits with accessory rider backrest. Includes rain cover for Tour-Pak® mounted passenger backrest.



G. RAIN COVER – SOLO SEAT

H. SERVICE COVERS*

Protect the finish on your tank and fenders while performing routine service on your motorcycle. These custom shaped covers feature an easy-to-clean black vinyl outer surface and a soft non-abrasive fleece inner liner. Fuel tank covers feature built-in magnets to prevent the cover from sliding, convenient mesh pockets to keep small parts from rolling away and a clear paperwork window for notes and instruction sheets. Fender covers feature soft elastic bands to keep the covers firmly in place. To complete the look, the cover features a nostalgic Harley-Davidson logo that will look great in any garage.

94640-08 Large Fuel Tank.
Fits Dyna®, Softail®, Touring and Trike models.

94641-08 Large Front Fender.
Fits '12-'16 FLD, '86-'17 FL Softail (except FLS and FLSS), '18-later FLDE, FLHC and FLHCS, and most Touring and Trike models.



H. SERVICE COVER



H. SERVICE COVER

*NOTE: H-D® motorcycle covers are not designed to be used while trailering. Using an H-D motorcycle cover while trailering may cause the cover to tear, possibly causing damage to the cover and motorcycle.



***WARNING:** Do not use while riding; could result in death or serious injury.

704 GARAGE

H-D® Detachables™ Storage

A. REMOTE CONTROL GARAGE DOOR OPENER KIT

Operate your automatic garage door opener without leaving your motorcycle seat or fumbling in your pocket for the remote control. Compatible with most brands of automatic openers, this kit allows you to operate your door by cycling the bike's high-beam switch. The hidden transmitter splices into your bike's wiring harness and is powered by your vehicle battery, so there are no transmitter batteries to replace. When your key is switched off the transmitter is disabled, providing added garage security if you park your bike outside. The signal is sent to the in-garage receiver that plugs into a standard 110-volt outlet and is wired to the automatic opener. The receiver's rolling code technology provides additional security. Kit includes one transmitter and one receiver. Individual components are available to equip additional motorcycles and garages.

91558-01B Complete Kit. Fits '02-'17 VRSC™, '15-'20 XG, '94-later XL, '08-'13 XR, '96-'17 Dyna, '96-later Softail®, and '94-later Touring and Trike models. '14-later XL, '12-'17 Dyna® and '11-'17 Softail models require separate purchase of Electrical Connection Kit P/N 72673-11. '14-'16 Touring and Trike models require separate purchase of Electrical Connection Kit P/N 69200722. '18-later Softail and '17-later Touring and Trike models require separate purchase of Electrical Connection Kit P/N 69201599A. '15-'20 XG models require separate purchase of P/N 72136-94GY, 72156-94 and Qty. 4 72195-94. Not compatible with Chamberlain®/Liftmaster® MyQ® or Sears® Craftsman AssureLink™ garage door openers.

1. Remote Control Garage Door Opener Transmitter

This kit allows owners of the Remote Garage Door Opener P/N 91558-01B to equip each of their Harley-Davidson® motorcycles with a remote transmitter.

91561-01B For use with Remote Control Garage Door Opener Kit P/N 91558-01B. '15-'20 XG models require separate purchase of P/N 72136-94GY, 72156-94 and 4x 72195-94. '14-later XL, '12-'17 Dyna and '11-'17 later Softail models require separate purchase of Electrical Connection Kit P/N 72673-11. '14-'16 Touring and Trike models require separate purchase of Electrical Connection Kit P/N 69200722. '18-later Softail and '17-later Touring and Trike models require separate purchase of Electrical Connection Kit P/N 69201599A.

2. Remote Control Garage Door Opener Receiver

This additional receiver permits the owner of the Remote Garage Door Opener P/N 91558-01B to operate more than one garage door opener from a single transmitter.

91562-01 For use with Remote Control Garage Door Opener Kit P/N 91558-01B. Not compatible with Chamberlain/Liftmaster MyQ or Sears Craftsman AssureLink garage door openers.

B. DETACH DEPOT WALL RACK

This heavy-duty Detach Depot Wall Rack can be mounted to any wall, and the 16 on-center design lets you mount it securely to the studs. The rack features 5 coated rods that can be positioned in a wide variety of adjustable mounting slots. Adjustable rods can accommodate almost any combination of accessories. Kit includes black-finished side panels, 5 coated rods, decorative end caps and all necessary mounting hardware.

93100005 For use with Harley-Davidson® Detachables and HoldFast™ products including Tour-Pak Mounting Racks, Sissy Bars, Luggage Racks, Rider Backrests and H-D Detachables-style Windshields. Quick-Release style Windshields and Rider Backrests require separate purchase of auxiliary mount kits.

C. DETACH DEPOT QUICK-RELEASE WINDSHIELD MOUNTS

93100015 For use with Harley-Davidson® Quick-Release Windshields (except XG) and Detach Depot Wall Rack P/N 93100005.

D. DETACH DEPOT RIDER BACKREST MOUNT

93100016 For use with Harley-Davidson® Touring and Trike Rider Backrest and Adjustable Rider Backrest Kits and Detach Depot Wall Rack P/N 93100005.



A. REMOTE CONTROL GARAGE DOOR OPENER KIT



B. DETACH DEPOT WALL RACK



C. DETACH DEPOT QUICK-RELEASE WINDSHIELD MOUNTS



D. DETACH DEPOT RIDER BACKREST MOUNT



E. CRUISER CRADLE WHEEL CHOCK

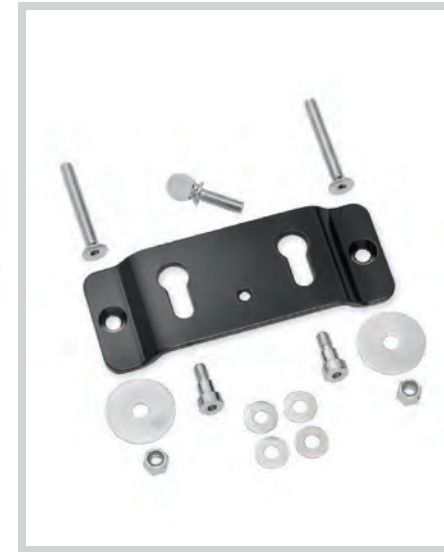

F. CRUISER CRADLE TRAILER ADAPTER KIT



G. CRUISER CRADLE WHEEL CHOCK - TRAILER ONLY VERSION



H. CRUISER CRADLE UNIVERSAL E-TRACK ADAPTER KIT (SHOWN WITH WHEEL CHOCK)



I. MOTORCYCLE SERVICE LIFT

GARAGE 705

Motorcycle Cradles & Tie-Downs

E. CRUISER CRADLE WHEEL CHOCK

This sturdy aluminum wheel chock will hold your bike securely on the ground, on a trailer or in the back of a pickup truck. Sized to fit most motorcycles, this wheel chock will keep your bike upright while you are storing, transporting or working on your bike. The lightweight, folding wheel chock is easy to transport. Use it on the driveway when you are washing your bike or, when equipped with the optional Trailer Adapter, the versatile wheel chock can be easily moved to a trailer or the back of a pickup truck. Just two tie-down straps are required to hold the bike in place. And because you don't need to over-tighten the straps, you won't damage sensitive suspension parts and handlebar bushings.

92900001 For use with models with vehicle weight up to 3000 lb (1360 kg) and front or rear wheel size of 14 to 22 (355-560mm) rim diameter and 3.15 to 8.66 (80mm-220mm) nominal wheel width. Not for use with Custom Wrapped Front Fenders.

F. CRUISER CRADLE TRAILER ADAPTER KIT

Engineered to simplify installation of Cruiser Cradle Wheel Chock on many trailers. Simply mount the low-profile kit to the floor of your trailer and the Cruiser Cradle can be attached in seconds, without tools.

92900002 For use with Cruiser Cradle Wheel Chock P/N 92900001 on trailer applications.

G. CRUISER CRADLE WHEEL CHOCK - TRAILER ONLY VERSION

Sized to fit most motorcycles, this wheel chock will keep your bike upright while you are transporting or working on your bike. Just two tie-down straps are required to hold the bike in place. The Trailer-Only chock can be removed from the trailer in seconds with four wing nuts or the optional E-Track Adapter and can be folded down when not in use. Includes all brackets and hardware to mount a trailer or lift table.

92900042 For use with models with vehicle weight up to 3000 lbs (1360 kg) and front or rear wheel size of 14 to 22 (355-560mm) rim diameter and 3.15 to 8.66 (80mm-220mm) nominal wheel width.

H. CRUISER CRADLE UNIVERSAL E-TRACK ADAPTER KIT

You can adjust the position of the chock anywhere along the E-Track for maximum flexibility in positioning a motorcycle and the chock can be adjusted side-to-side between 27 and 43 wide. The Universal E-Track Adapter Kit includes all the necessary hardware and including a Boomerang Bar for added Wheel Chock stability. Ratchet tie-downs are required for transporting the motorcycle.

92900043 For use with Cruiser Cradle Wheel Chock P/N 92900001 or 92900042 on trailer applications.

I. MOTORCYCLE SERVICE LIFT

The 1,100 lb capacity lift can raise any 2-wheel Harley® model 16.9 from the floor. The lift features 2 fixed and 2 swivel heavy duty wheels and a removable T-handle for easy maneuverability. Kit includes lift and 2 tie-down straps. Not available for sale in Europe, Middle East and Africa.

92900004 Fits Harley-Davidson® V-Twin models (except Trike and models equipped with a Sidecar). Softail® models require Frame Protector Kit P/N 94675-99. Twin Cam-equipped Dyna® models require Adapter Kit P/N 98965-99, both sold separately.

706 GARAGE

Motorcycle Tie-Downs

A. HARLEY-DAVIDSON® 1.5 GRADUAL RELEASE RATCHET TIE-DOWN STRAPS

600 lbs Working Load – 1.5 x 66

These heavy-duty ratchet straps provide maximum tensioning power and a higher working load capacity with the added benefit of being able to release the tension one click at a time. The ratchet is built with a comfortable molded grip handle and a dual-direction reversing drive that permits the spindle to rotate backward releasing tension until it reaches 60 lbs. This option helps eliminate the snap back release common with most standard ratchet designs under heavy load and also permits the even tensioning of straps without having to release all of the webbing and start over. The strap also features heavy-duty 6,000 lb abrasion-resistant Nylon webbing, a built in Soft Hook with vinyl coated full-size S hook on the fixed end and a large closed end carabiner hook on the adjustable end to keep it hooked securely during the tie-down process. Sold in pairs.

94706-10
Ratchet Straps with Integrated Soft Hook.



A. 1.5 GRADUAL RELEASE RATCHET TIE-DOWN STRAPS

B. HARLEY-DAVIDSON 1.25 RATCHET TIE-DOWN STRAPS

400 lbs Working Load – 1.25 x 78

These 1.25 Harley-Davidson® Tie-Downs have a 1,200 lb capacity and feature Harley-Davidson scripted webbing with a loop handle for easy pulling. Vinyl-coated hooks feature spring loaded one-way wire loop gates that hold the hook in position, simplifying initial tie-down setup. Harley-Davidson Ratchet Tie-Down Straps feature lever-action ratchets for use when greater tensioning power is needed. Straps are also available with integrated soft hooks that are designed to keep the coated hard hooks away from delicate surfaces. Sold in pairs.

94704-10
Ratchet Straps with Integrated Soft Hook.



B. HARLEY-DAVIDSON 1.25 RATCHET TIE-DOWN STRAPS

C. HARLEY-DAVIDSON FLEECE SOFT HOOKS

400 lbs Working Load – 1.25 x 18

These 18 Soft Hooks are designed to keep ratchets, hooks and buckles away from delicate surfaces. The soft synthetic sheepskin cover cushions the surface and protects handlebars, triple trees and other tie-down points from scratches and abrasion. Each soft hook has a capacity of 2,400 lbs. Sold in pairs.

93100017



C. HARLEY-DAVIDSON FLEECE SOFT HOOKS

D. HARLEY-DAVIDSON SOFT HOOKS

400 lbs Working Load – 1.25 x 18

These Harley-Davidson 18 Soft Hooks keep ratchets and buckles away from delicate surfaces. Each soft hook has a capacity of 2,400 lbs. Sold in pairs.

94705-10



D. HARLEY-DAVIDSON SOFT HOOKS

E. HOG TIES® SOFT HOOKS

600 lbs Working Load – 1.5 x 18

Wider and stronger, Hog Ties® Soft Hooks are designed to be used in conjunction with standard Hog Ties Straps to keep hooks from direct contact with handlebars, fairings, brake lines, wiring and painted surfaces. Secure to bike then secure tie-down hook to opposite end. Made with 6,000 lb Nylon webbing. Sold in pairs.

94650-98



E. HOG TIES SOFT HOOKS

F. ANCR A® RAT-PACK RATCHET STYLE TIE-DOWN STRAPS

400 lbs Working Load – 1 x 66

The original ratchet tie-down for motorcycles locks secure and provides the added tension needed to secure bikes and ATVs for longer hauls. Straps feature a wider grip ratchet handle, 4,500 lb abrasion-resistant nylon webbing, full-size vinyl coated S hooks on fixed ends and non-coated steel S hooks on the adjustable ends. Sold in pairs.

98187-90T

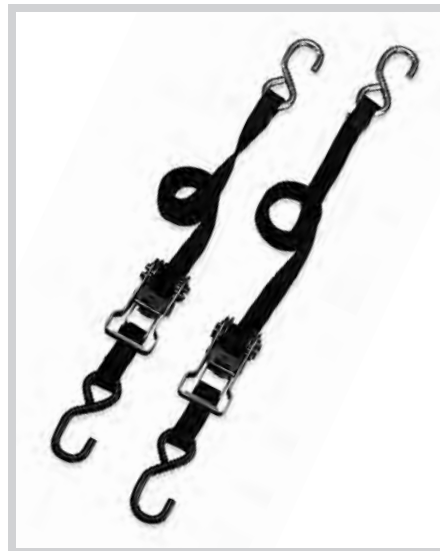

F. ANCR A RAT-PACK RATCHET STYLE TIE-DOWN STRAPS



G. SECURITY ANCHOR



G. SECURITY ANCHOR INSTALLATION KIT

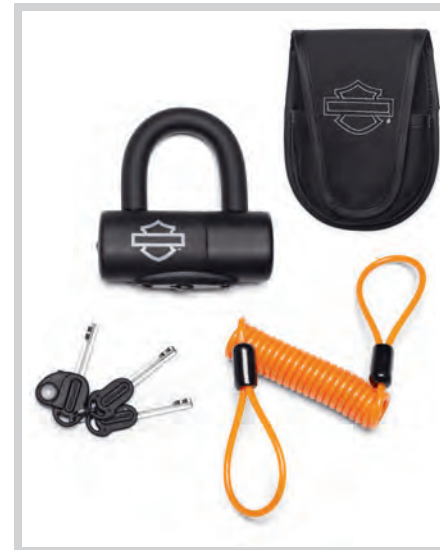

H. DISC BRAKE & ROTOR LOCK*



I. SIREN DISC BRAKE LOCK

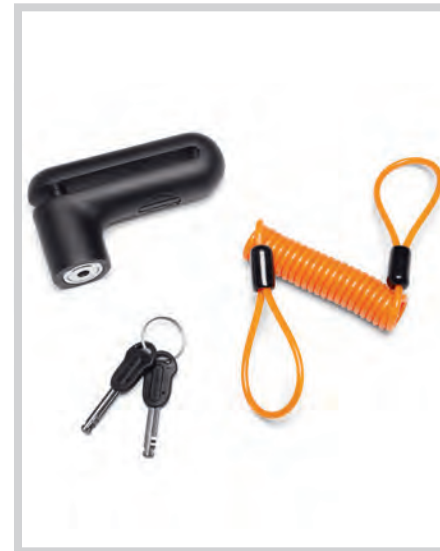

J. DISC BRAKE LOCK*



K. LOOP CHAIN AND DISC BRAKE & ROTOR LOCK*

GARAGE 707

Motorcycle Locks

G. SECURITY ANCHOR

Lock down that motorcycle. This rugged Security Anchor is designed to create a permanent anchor point for use with security chains and locks. Secure it to your truck or trailer bed or to a garage floor. Includes masonry drill bit and bolts necessary to install into concrete. Corrosion resistant. Recommended to be used with Harley-Davidson® chains and locks, such as Loop Chain and Disc Brake & Rotor Lock (P/N 94869-10A). Recommended to be used with Harley-Davidson Security Anchor Installation Kit (P/N 12600354) for use on trailers or truck beds.

92800013

Also available:

SECURITY ANCHOR INSTALLATION KIT

Required for installation of the Harley-Davidson Security Anchor (P/N 92800013) to a trailer or truck bed. For security use only, not to be used as a tie-down point

12600354

H. DISC BRAKE & ROTOR LOCK*

Secure your brake disc or sprocket. This lock features a fully removable 14mm lock with a large inside diameter to simplify the capture of chain links and cable loops. High-security double deadbolt design and tough-defeat lock cylinder. Soft vinyl coating on the lock protects your bike's finish. Corrosion resistant. Includes two standard keys, one lighted key, high visibility reminder cord, and a compact ballistic nylon storage pouch with belt clip. Limited lifetime manufacturer warranty*.

94868-10A Black.

Also available:

LOCK REMINDER CORD¹

Remember to remove your Disc or Fork Lock before beginning your ride with this high-visibility Reminder Cord. Flexible, coiled, bright orange cord loops from external lock to handlebar, acting as a visual indication that your lock is still engaged.

46318-04

I. SIREN DISC BRAKE LOCK

Designed to discourage roll-away theft, this rugged lock easily attaches to your disc brake and sounds a piercing alarm if the motorcycle is moved. Physical movement triggers a piercing 120dB audible alarm that acts as an additional theft deterrent. Audible alarm can be deactivated by key if only mechanical security is desired. 0.23 in (6 mm) diameter hardened-steel locking pin. Corrosion resistant. Includes two keys, high visibility reminder cord, and Lithium (CR2) battery. Limited lifetime manufacturer warranty; 2-year battery warranty *

92800012

J. DISC BRAKE LOCK*

Designed to discourage roll-away theft, this lock easily attaches to your disc brake. Compact and lightweight so it's easy to carry along in luggage or backpack. Easy to install on the front brake disc. Hardened drop-forged steel lock features a dual-reinforced high-security disc-style cylinder. Corrosion resistant. Includes two keys and high-visibility reminder cord.

94873-10A Black.

K. LOOP CHAIN AND DISC BRAKE & ROTOR LOCK*

Maximum protection for your motorcycle. This high-security Loop Chain features a 12mm triple heat treated boron manganese 6-sided link steel chain with cinch ring for securing your bike to stationary objects. Loop chain length: 4.25 ft (129 cm). Fully removable Disc Brake & Rotor Lock has a high-security double deadbolt design and tough-defeat lock cylinder, with a soft vinyl coating on the lock to protect your bike's finish. Corrosion resistant. Includes a fully removable 14mm lock, a double deadbolt design for added security, a high-security lock cylinder with anti-float discs and nylon molded dust cover, and a lighted key for nighttime locking. Limited lifetime manufacturer warranty*.

94869-10A Black.

! WARNING: Remove lock before operating motorcycle. Failure to remove lock could result in death or serious injury.

***KEY SAFE** registration and replacement service is provided by the lock manufacturer. Information is included in the product packaging.

708 GARAGE

Motorcycle Locks

A. DOUBLE LOOPED SECURITY CABLE*

For use with a lock, this vinyl-covered multi-purpose cable can be used to secure your personal items to your motorcycle or solid object. Loop it through the sleeve of your jacket and the strap of your helmet, lock it to the bike, and feel free to walk away unencumbered. 7 ft (213 cm) length x 0.4 in (10mm) thick. Corrosion resistant vinyl coating makes cable easy to handle. Hook-and-loop strap lets you secure the coiled cable for convenient storage. Recommend to be used with a Harley-Davidson® Disc Brake & Rotor Lock (P/N 94868-10A)

94871-10A

B. ARMORED CABLE LOCK

This tempered steel cable lock features a smooth vinyl cover to protect the frame and wheel from scratches. The braided cable offers improved cut resistance, and the integrated lock features a snap-shut cylinder with quarter-turn key movement. Kit includes 2 blade-style keys. Cable length: 6 ft (183cm). Cable is encased by hardened steel links to provide increased security. Corrosion resistant. Limited lifetime manufacturer warranty*

46089-98B

C. UNIVERSAL MOUNT HELMET LOCK

Lock your lid. This Universal Helmet Lock secures your helmet through its D-Rings directly to the motorcycle so the helmet can't be dropped or stolen. Easy to use – clicks into the locked position without fumbling with the key while holding the helmet. Mounts to tubes from .875 to 1.25 in diameter, including most handlebars, engine guards or bag guards, so you can select the most-convenient location on your bike. Includes tamper-proof and standard mounting screws so the lock may be permanently or temporarily attached to the motorcycle. Scratch resistant backing won't mar up the motorcycle finish.

.875 to 1.25 diameter tubing.

92800019 Chrome.

92800020 Black.

D. RETRACTABLE CABLE LOCK*

This multi-purpose retractable cable easily secures your personal items to your motorcycle or solid object, and is small enough to carry in a pocket or backpack. Slip it through a jacket sleeve or a helmet loop and secure to your bike or a fixed object. 3 ft (90 cm) cable length is long enough to secure many different personal items. Compact, lightweight, and easy to use so you never need to leave it at home. 4-digit resettable combination can be personalized so it's easier to remember. Universal fit

92800018

E. HARLEY-DAVIDSON HELMET/JACKET SECURITY CABLE²

This handy cable is a great complement to the Harley-Davidson® Helmet Lock. Slide one end through your jacket sleeve or luggage, hook the loops at the end of the cable onto the Helmet Lock and attach it to your bike. And, if your helmet does not have D-rings, you can pass the cable through your helmet's chin piece, loop the ends through your Helmet Lock and lock it to your bike. Now your jacket, luggage and helmet are locked to your bike. When you're finished, it will recoil back to its original length and will slip easily into your pocket. The cable is made from 3mm thick nickel plated steel cable, is only 4.5 inches (11cm) long when coiled, stretches up to 6ft (180 cm) and has a load capacity of 200 lbs (100 kg).

52200004



A. DOUBLE LOOPED SECURITY CABLE*



B. ARMORED CABLE LOCK

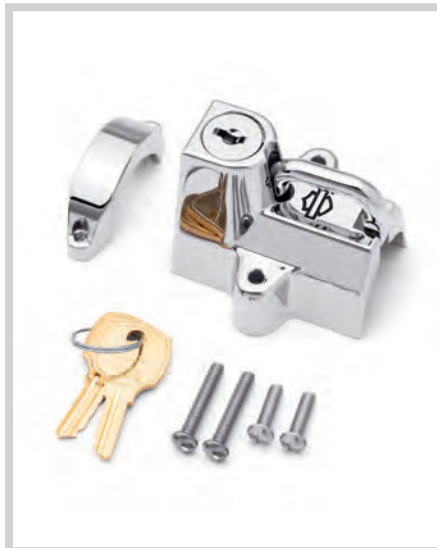

C. UNIVERSAL MOUNT HELMET LOCK – CHROME

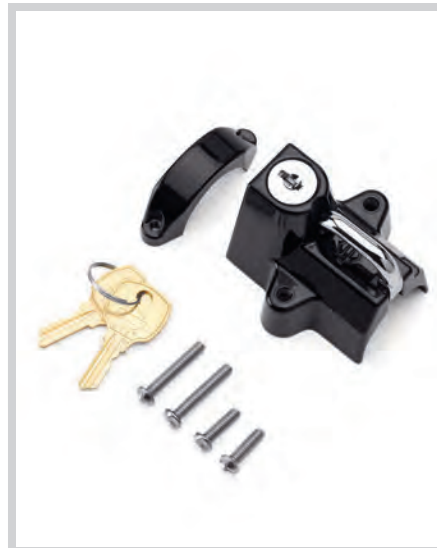

C. UNIVERSAL MOUNT HELMET LOCK – BLACK



D. RETRACTABLE CABLE LOCK*



E. HARLEY-DAVIDSON HELMET/JACKET SECURITY CABLE



F. LOCKING H-D DETACHABLES LATCH KIT – BLACK

KEY SAFE AVAILABLE



G. HOLDFAST LOCKING LATCH – CHROME

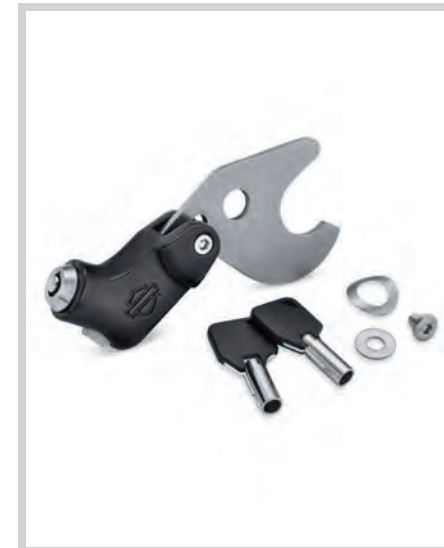

G. HOLDFAST LOCKING LATCH – BLACK



H. UNIVERSAL SADDLEBAG LOCK KIT

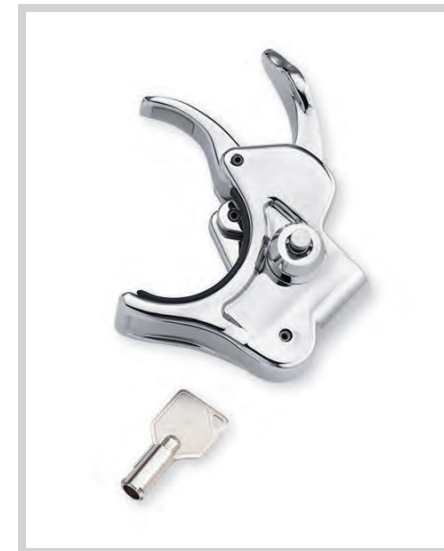

I. LOCKING QUICK-RELEASE WINDSHIELD CLAMP

GARAGE 709

Motorcycle Locks

F. LOCKING H-D® DETACHABLES™ LATCH KIT

This unique lock replaces the cam-lock on your Harley-Davidson® Detachables™ accessories, providing additional security and peace of mind when parking your vehicle. Kit includes two extended-reach barrel-style keys for easy access to the lock. Key registration and replacement service is available. Sold in pairs.

Fits all models equipped with detachable Sideplates, Racks and Tour-Pak® Luggage Carriers (except '18-later Softail® models with HoldFast™ racks and uprights or '09-later Touring models equipped with detachable Solo Tour-Pak Rack).

92800008 Black.

G. HOLDFAST™ LOCKING LATCH

Secure your valuables. This locking system allows you to protect your HoldFast™ Sissy Bar, Luggage Rack or Tour-Pak Mounting Rack from theft, providing security and peace of mind when parking your vehicle. The kit includes (2) keys and (1) locking mechanism

Fits '18-later Softail models equipped with HoldFast detachable Sissy Bar, Luggage Rack or Solo Tour-Pak Mounting Rack.

52300513 Chrome.

52300514 Black.

Fits '18-later FLHC, FLHCS and FLDE models equipped with HoldFast detachable Two-Up Tour-Pak Mounting Rack.

52300518 Chrome.

52300519 Black.

H. UNIVERSAL SADDLEBAG LOCK KIT

Keep the contents of your existing soft-sided saddlebags safe from the grab-and-go thief. This unique kit features two extra-small barrel locks that can replace existing saddlebag snaps to perform double duty as locks or as snaps when you don't need to lock your bags. Can be keyed to match your barrel-style ignition key. Sold in pairs.

Fits most soft-sided leather and vinyl saddlebags. Does not fit FLHRC and FLHRS.

90300003 Keyed To Match.

90300017 Random Key Code.

I. LOCKING QUICK-RELEASE WINDSHIELD CLAMP

Protect your investment. This Locking Quick-Release Windshield Clamp secures your windshield from grab-and-run theft, giving you peace of mind when you have to leave your bike unattended. The chrome-plated Locking Clamp replaces one of the Original Equipment windshield clamps, and features a push-button lock with a mini barrel-style key for easy removal. Kit includes one locking clamp and two matching keys.

57400536 39mm.

Fits '88-later XL (except '16-later XL1200CX and XL1200X) and '91-'05 Dyna® models (except FXDWG) equipped with Quick-Release style windshields.



***WARNING:** Chain or cable is to be used as a theft deterrent only. Use for towing, lifting or any other purpose could result in death or serious injury.

***KEY SAFE** registration and replacement service is provided by the lock manufacturer. Information is included in the product packaging.

710 GARAGE

Security Systems

A. H-D® SMART SECURITY SYSTEM – '07-LATER MODELS

The H-D® Smart Security System offers automatic self-arming and hands-free disarming for vehicle electronic security functions for your '07-later Harley® motorcycle. The Hands-Free Fob communicates directly on its own unique and individualized frequency with the Hands-Free Security Module and Antenna. Attach the Hands-Free Fob to your vehicle ignition key ring. As you upright your vehicle or switch the ignition on, the Hands-Free Fob will communicate the Security System disarm command allowing you to start your vehicle. After riding your vehicle, park and switch the ignition off with your key. Within 5 seconds the Security System will automatically self-arm, disabling your vehicle starter, ignition and electronic fuel injection (EFI). The Smart Security System includes Hands-Free Security Module (Integrated Security Sensor and Turn Signal Module or Body Control Module), 2 Hands-Free Fobs, Antenna Module, Antenna Harness and Antenna Mount (Dyna® models).

Also available:
H-D SMART SECURITY SYSTEM HANDS-FREE FOB
 Replacement/Additional Hands-Free Fob.

68926-07
 Fits '07-'16 models (except '16 CVO™) equipped with H-D Smart Security System. Requires activation. See your Harley-Davidson® dealer.

90300111
 Fits '17-later XL, Dyna®, Softail®, Touring and Trike models equipped with H-D Smart Security System. Does not fit Japan models. Dealer installation required.

90300117
 Fits '17-'20 XG models equipped with H-D Smart Security System. Requires activation. See your Harley-Davidson dealer.



A. H-D SMART SECURITY SYSTEM – '07-LATER MODELS

B. H-D FACTORY SECURITY SYSTEM – '06-EARLIER MODELS

Equip your '06-earlier Harley-Davidson® VRSC™, Sportster®, Dyna, Softail or Touring model with the security system designed and approved by The Harley-Davidson Motor Company.

When armed, the Security System disables the starter and ignition while monitoring the electrical system and vehicle motion with adjustable sensitivity. Minor disturbances trigger a momentary warning; major ones, an unbroken thirty-second alarm, after which the Security System returns to monitoring. A distinctive four-way flasher pattern is the alarm signal. An optional self-powered Smart Siren Kit adds a piercing scream that sounds even if the battery cable is cut.

The Security System is armed and disarmed with a remote control waterproof key fob utilizing state-of-the-art rolling code technology. If the key fob is not available, the rider may arm or disarm the system by keying a previously entered personal code on the turn signal switches. Kit includes 1 Key Fob.

Also available:
REPLACEMENT/ADDITIONAL REMOTE CONTROL WATERPROOF KEY FOB

68926-00
 Fits '00-'06 models equipped with H-D Factory Security System, North America. Requires activation. See your Harley-Davidson dealer.

68927-00
 Fits '00-'06 models equipped with H-D Factory Security System, International (except Japan). Requires activation. See your Harley-Davidson dealer.

Also available:
LITHIUM REPLACEMENT BATTERY – 3 VOLT
 Long-lasting, replaceable lithium coin-type battery for use in LED Temperature Dipsticks with Lighted LED Readout, Digital Touring Suspension Air Pump P/N 54000033 and Security Hands-Free Key Fob.

66000107
 CR2032 3V Lithium Replacement Battery.



A. H-D SMART SECURITY SYSTEM – '07-LATER MODELS
 (41000021G & 41000087F SHOWN)



A. H-D SMART SECURITY SYSTEM – '07-LATER MODELS
 (68200-07A, 68207-07A & 91684-08A SHOWN)



B. H-D FACTORY SECURITY SYSTEM – '06-EARLIER MODELS
 (68200-00D & 68207-00D SHOWN)

GARAGE 711

Security Systems

C. H-D® SECURITY SYSTEM SMART SIREN II

If your bike is equipped with an Original Equipment or accessory H-D® Smart Security System, this Smart Siren provides added security and convenience in one. The Harley-Davidson® Smart Siren II combines the functionality of the smart siren and pager transmitter into one easy-to-install unit. Featuring a built-in back-up power supply, the siren and transmitter functions will continue to operate even if the wires are cut or the vehicle battery is disconnected. When combined with the Pager Receiver II (sold separately), the integrated FM transmitter can warn of tampering up to 1/2 mile away. Smart Siren II features an enhanced sound chamber, a redesigned internal battery access cover and ultra-low power consumption during the standby mode. When activated, the Security System Fob arm and disarm commands are confirmed with a blink feature and '07-later models can be programmed to emit a chirp. Smart Siren II is certified for use in North America.

Also available:
SMART SIREN BATTERY REPLACEMENT KIT (not shown)
 Replacement Battery Kit for Harley-Davidson Factory Security System Smart Siren includes replacement nickel metal hydride battery and instructions.

69309-10



C. H-D SECURITY SYSTEM SMART SIREN II

H-D SECURITY SYSTEMS, NORTH AMERICA

Model Family	Model Year	Security System	Smart Siren II Kit**
VRSC™ (except VRSCF)	2007-2017	68207-07A	68328-06A
VRSCF	2009-2017	91684-08A	68328-06A
VRSC (except VRSCR)	2002-2006	68200-00D	68328-06A
VRSCR	2006	68207-00D	68328-06A
Trike	2009-2013	68200-07A	68328-06A
Touring and Trike	2014-later	41000087F	68328-06A
Touring	2007-2013	68200-07A*	68328-06A
Touring	2002-2006	68200-00D*	68328-06A
Touring	2000-2001	68200-00D*	68317-06A
Dyna®	2012-2017	41000087F	68328-06A
Dyna	2007-2011	68207-07A	68328-06A
Dyna	2004-2006	68207-00D	68328-06A
Dyna	2000-2003	68200-00D	—
Softail®	2011-later	41000021G	68328-06A
Softail (except FXCW/C)	2007-2010	68207-07A	68328-06A
Softail FXCW/C	2008-2010	91684-08A	68328-06A
Softail	2003-2006	68207-00D	68328-06A
Softail	2001-2002	68207-00D	—
XL	2014-later	41000087F	68328-06A
XL/XR	2007-2013	68200-07A	68328-06A
XL	2004-2006	68200-00D	68328-06A

*P/N 88115-03 Bank Angle Switch Kit (sold separately) or Security System P/N 68200-00D or 68200-07A are required for use on 2000-2013 FL Touring models equipped with a TLE/Ultra Sidecar.

**Pager function requires Remote Pager Receiver II P/N 91660-06 or 91672-07 (sold separately).

***'17-later XG models require separate purchase of siren mounting bracket P/N 69201473.

712 GARAGE

Security & Keys

A. INTEGRATED SECURITY & LOCKING FLIP FOB

This hands-free fob automatically arms and disarms its electronic security functions as you approach and walk away from the bike. Keyed to match all your bike's locks, the combination fob with fold-away retractable barrel key lets you save room on your key ring and let one device do all the work.

90300118

Fits '17 Dyna® and Softail®, and '17-later Touring and Trike models equipped with H-D® Smart Security System. Does not fit Japan models. Key code required when ordering. Dealer installation required.

B. KEYED-TO-MATCH INDIVIDUAL REPLACEMENT LOCK PROGRAM

In the past, replacing a lock required the time and expense of re-keying a new lock or replacing all of the locks on your bike. Our Keyed-to-Match Program eliminates that hassle and allows you to order an exact replacement based on your lock's key code, right down to the quality you would expect from a stock Harley-Davidson® lock. Just ask your Dealer to refer to Bulletin Number 658B and they'll take care of your needs – lock, stock and barrel.

C. KEYED-TO-MATCH CUSTOM KEYS

Custom keys make a statement. Keys can be ordered through your Harley-Davidson® Dealer and will be keyed to match your ignition and fork lock and they are delivered in a leatherette gift box.

1. Commemorative CVO™ Model Ignition Key

Hand-polished brass key features a prismatic Bar & Shield logo set in a black field surrounded by Custom Vehicle Operations script. Available to CVO™ vehicle owners only.

71031-04 Barrel Style.

Fits '91-later models with barrel-style key.

2. Skull Ignition Keys

Key features the Harley-Davidson Skull logo in bright nickel with black accents.

71040-04 Barrel Style.

Fits '91-later models with barrel-style key.



A. INTEGRATED SECURITY & LOCKING FLIP FOB



A. INTEGRATED SECURITY & LOCKING FLIP FOB



B. KEYED-TO-MATCH INDIVIDUAL REPLACEMENT LOCK



C. KEYED-TO-MATCH CUSTOM KEYS



D. HARLEY-DAVIDSON SECURITY SYSTEM PAGER RECEIVER II – BATTERY POWERED



E. HARLEY-DAVIDSON SECURITY SYSTEM PAGER RECEIVER II – RECHARGEABLE



F. COTTON WINDSHIELD STORAGE BAG



G. HELMET HANGER – J-HOOK



H. JIFFY STAND COASTER

GARAGE 713

Security

HARLEY-DAVIDSON® SECURITY SYSTEM PAGER RECEIVER II

Designed to complement the Smart Siren II, this Pager Receiver can be linked to the vehicle with no additional installation. The Pager Receiver II monitors the Security System operation, and features multi-color LED indicators to display unique codes for arming, disarming and trigger modes. The Range Confirmation Signal (RCS) confirms and displays the signal reception. High-efficiency FM circuitry provides excellent reception, even in buildings and parking garages. Maximum effective range is up to 1/2 mile. The Pager Receiver II features selectable vibration or audible modes. The silent paging mode feature allows selectable programming trigger modes to avoid activating the siren.

D. PAGER RECEIVER II – BATTERY POWERED

The convenient built-in ultra-bright white LED flashlight helps light the way. The compact, lightweight receiver can be carried in your pocket, or the receiver holster can be clipped to a belt up to 1-3/4 wide. Kit includes receiver, holster and one 3V lithium battery. Operates in conjunction with the Security System Fob and Smart Siren II.

91660-06

Fits all models equipped with the Harley-Davidson® Security System Smart Siren II. Certified for use in North America.

E. PAGER RECEIVER II – RECHARGEABLE

The compact, lightweight receiver can be carried in your pocket or clipped to a belt. Kit includes receiver and UL-listed battery charger (AC-DC with output of DC 4.5V 50mA for North America). Operates in conjunction with the Security System Fob and Smart Siren II.

91672-07

Fits all models equipped with the Harley-Davidson Security System Smart Siren II. Certified for use in North America.

F. COTTON WINDSHIELD STORAGE BAG

This bag is constructed of breathable cotton material and is designed for a scratch-free storage area. The outside of the bag features an embroidered Bar & Shield logo to match the cotton cycle covers.

95982-98B

Fits all Harley-Davidson® windshields.

G. HELMET HANGER

Proudly display your collection of helmets. Harley-Davidson® Helmet Hangers keep your expensive helmet safe and out of the way. Designed to accommodate all types of helmets, these Helmet Hangers allow air to circulate inside to keep the liner fresh and dry. The rigid steel hooks feature a durable e-coated surface and soft rubber edges to protect the finish of the helmet. The wall-mount J-Hook design can be secured to a trailer wall, garage wall or most any flat surface. The universal S-Hook design hangs on doors, cubicle walls and closet rods.

93100034 J-Hook.

H. JIFFY STAND COASTER

Designed for use beneath the jiffy stand, this polypropylene coaster prevents the stand from sinking into soft surfaces such as dirt, asphalt and grass.

94647-98

Fits motorcycles equipped with a sidestand.

H-D® BATTERY CHARGERS

These new H-D® chargers are designed to do more than just charge your H-D® motorcycle battery. These chargers will effortlessly charge multiple battery voltages (6 and 12 volt) with chemistries such as flooded, gel, AGM and Lithium. You can also charge different types of batteries such as deep-cycle, marine, powersport and more. The chargers are completely automatic. You can leave these chargers plugged in 24/7 with no worries of overcharging. Best of all there is no technical knowledge required. Chargers are designed for use in any climate, altering each charge based on the ambient temperature and providing a more accurate recharge.

Additional Features

SMART INDICATORS

H-D Chargers have smart indicators and diagnostics to quickly detect when the battery charger is connected in reverse polarity, connected to an incompatible battery, or if the battery is failing. These Chargers provide simple troubleshooting using advanced diagnostics



- Battery Failure
- Reverse Polarity
- High Voltage
- Standby

ERROR CONDITIONS PROVIDED

- Battery Below Start Voltage
- Reverse Polarity
- Battery Will Not Hold Charge
- Bulk Charge Timeout
- Battery Above Protection Voltage
- Charger Internal Temperature Too High
- Charger Ambient Temperature Too Cold

BRING BATTERIES BACK TO LIFE

- Auto Desulfation mode
- Auto Detection mode
- Auto Repair mode

	SMART INDICATORS	ERROR CONDITIONS PROVIDED	BRING BATTERIES BACK TO LIFE
1AH DUAL-MODE		✓	✓
2AH DUAL-MODE		✓	✓
5AH DUAL-MODE		✓	✓



A. 1 AMP DUAL-MODE BATTERY CHARGER



B. 2.0 AMP DUAL-MODE BATTERY CHARGING STATION



C. 5.0 AMP DUAL-MODE BATTERY CHARGER

A. 1 AMP DUAL-MODE BATTERY CHARGER

This fully-automatic Harley-Davidson® Dual-Mode Battery Charger is ideal for short- or long-term motorcycle battery charging needs. Selectable charge options provide optimal charging for Harley-Davidson™ Lithium LiFe or AGM Lead-Acid batteries. Can be used to charge 12 volt and 6 volt batteries. Can be used with existing Harley-Davidson™ battery charging cords - no additional charging cords needed. Maximum charge rate of 1 amp. Harley-Davidson tested and validated. Backed by a 5-year limited warranty.

66000304

For use within the United States, Canada, Mexico and South America

66000308

For use within Europe, Middle East and Asia

66000305

For use within the United Kingdom

66000307

For use within Australia

66000306

For use within Japan

B. 2.0 AMP DUAL-MODE BATTERY CHARGING STATION

Keep all your bikes fully charged and ready to ride. This fully-automatic 4-bank Harley-Davidson® Dual-Mode Battery Charger is perfect for short- or long-term motorcycle battery charging needs. 4-bank charging station can charge and maintain up to 4 batteries at once. Selectable charge options provide optimal charging for Harley-Davidson™ Lithium LiFe or AGM Lead-Acid batteries. Can be used to charge 12 volt and 6 volt batteries. Can be used with existing Harley-Davidson™ battery charging cords - no additional charging cords needed. Maximum charge rate of 2 amp. Harley-Davidson tested and validated. Backed by a 5-year limited warranty

66000319

C. 5.0 AMP DUAL-MODE BATTERY CHARGER

This fully-automatic Harley-Davidson® Dual-Mode Battery Charger is perfect for short- or long-term motorcycle battery charging needs. Selectable charge options provide optimal charging for Harley-Davidson™ Lithium LiFe or AGM Lead-Acid batteries. Can be used to charge 12 volt and 6 volt batteries. Can be used with existing Harley-Davidson™ battery charging cords - no additional charging cords needed. Features repair mode for AGM batteries. Maximum charge rate of 5.0 amp. Harley-Davidson tested and validated. Backed by a 5-year limited warranty .

66000309

For use within the United States, Canada, Mexico and South America

66000313

For use within Europe, Middle East and Asia

66000310

For use within the United Kingdom

66000312

For use within Australia

716 GARAGE

Charging Accessories

A. HOG® BOOSTER PORTABLE BATTERY PACK

Think of it as a kick start for your weak battery. This lightweight, compact lithium powered battery pack is ready and waiting to jolt your battery back to life. Small enough to fit in your saddlebag or backpack, this 1000 amp portable battery pack will restart your motorcycle in seconds. The HOG® Booster easily connects to your motorcycle battery with high-quality alligator clips, and the sparkproof and reverse polarity protected connections help protect your bike's electrical system.

The HOG Booster's internal lithium battery can be recharged anywhere—from a wall outlet using your cell phone charging block, from your computer's USB port or from a 12V power outlet (with the included adaptor). A fully charged HOG Blaster will start up to 20 dead batteries. HOG Booster can also power and charge USB devices like cell phones and cameras to keep you in touch while on the road. The HOG Blaster also features a built-in 100 lumen flashlight with high, low and strobing SOS modes so you have a light source when you need it.

Complete kit includes HOG Booster unit, high-quality alligator clips and cables, 12V/cigarette lighter adaptor, handy storage bag and easy-to-read instruction manual.



A. HOG BOOSTER PORTABLE BATTERY PACK

Technical Data:

Internal Battery = Lithium Ion

Peak Current Rating = 1000A

Joules = 7000J

Micro USB (Input) = 5V, 2.1A

USB (output) = 5V, 2.1A

Weight = 2.4 lbs.

Flashlight Lumens = 100

USB Charger Rating = .5A–12 hrs; 1A–6 hrs; 2A–3 hrs.

66000130 For US and Canada markets.

66000147 For Europe, Middle East, Africa, Asia Pacific markets.



B. BATTERY BOOSTER TRAVEL CASE

B. BATTERY BOOSTER TRAVEL CASE

This durable and rugged case will make it easy to transport and protect your Harley-Davidson Booster Portable Battery Pack (high-quality alligator clips and cables, 12V/Cigarette lighter adaptor and USB cable) wherever your travels will take you.

Designed for Booster Portable Battery Pack P/N 66000130 or 66000147 (sold separately).

66000347

C. BATTERY CHARGING HARNESS WITH LED CHARGE INDICATOR

This Battery Charging Harness features an integrated LED indicator light that illuminates when your battery voltage drops to a level that requires charging. Just attach the ring terminals to your battery and route the harness for easy access to the plug connector. When the LED glows, it's time to connect the bike to a Harley-Davidson® Battery Charger. Compatible with all Harley-Davidson Battery Chargers, the harness features in-line 7.5 amp fuse protection, and the plug connector is protected with a weather-shield cap when not in use.

66000005

For use with Harley-Davidson 12-volt batteries.



D. BATTERY CHARGING HARNESS

D. BATTERY CHARGING HARNESS

Heavy-duty Battery Charging Harness with ring terminals and in-line 7.5 amp fuse protection for attachment to a Harley-Davidson 12-volt battery. The wiring harness utilizes a plug connector that is compatible with all Harley-Davidson Battery Chargers equipped with black connectors. The ring terminals are attached to the battery with the harness routed to allow access for the plug connector attachment to a H-D® Battery Charger. The harness plug connector is protected with an attached weather-shield cap when not in use.

94624-97B

For use with Harley-Davidson 12-volt batteries.

E. BATTERY CHARGING EXTENSION LEAD

Low-loss leads feature the same quick-disconnect 2-prong plugs as found on the charger unit and the available charging harnesses.

For use with most Harley-Davidson Battery Chargers.

99821-09 12.5'

99828-09 25'



E. BATTERY CHARGING EXTENSION LEAD

C. BATTERY CHARGING HARNESS WITH LED CHARGE INDICATOR



C. BATTERY CHARGING HARNESS WITH LED CHARGE INDICATOR



F. LITHIUM LIFE BATTERIES



G. H-D AGM BATTERIES

Motorcycle batteries built and rigorously tested to Harley-Davidson's exacting requirements. H-D® AGM battery ratings are determined by the strict regulations and testing of the Battery Council International.

! WARNING: Battery posts, terminals and related accessories contain lead compounds, chemicals known to the State of California to cause cancer and birth defects.

GARAGE 717

Batteries

F. LITHIUM LIFE BATTERIES

Power up with lithium Life battery technology, offering unequalled cranking power and a significant weight reduction over an AGM lead acid battery. Quality and performance backed by a 5-year limited warranty. A drop-in replacement for the Original Equipment battery with no fit adaptor or foam blocks required. Up to twice the life span of AGM lead acid battery*. When disconnected from the motorcycle a lithium battery will maintain its charge without maintenance for up to 12 months. The internal solid-state Battery Management System automatically detects over/under charging for more-reliable starting performance and protects the battery from deep discharge, over voltage and over temperature. For optimal charging, use a Harley-Davidson® Dual Mode Battery Charger (sold separately).

*Follow storage instructions for optimal service life

Note: Lithium batteries are not for everyone as they differ from AGM in terms of powering certain accessories or bikes that have been heavily modified from stock configurations. Be sure to ask your H-D® dealer if a Lithium battery is right for your application and use.

66000301 4AH
Fits '15-later XG, '04-later XL and '08-'13 XR models.

66000302 7AH
Fits '07-'17 VRSC™ (except '07 VRSCR), '97-'03 XL, '97-'17 Dyna®, '97-later Softail® models.

66000303 8AH
Fits '04-later Touring and '09-later Trike models

G. H-D® AGM BATTERIES

Fits '07-'17 VRSC (except '07 VRSCR), '97-'03 XL, and '97-'17 Dyna and '97-later Softail models. Also fits Buell™ S1, S3/T, M2, and X1 models.

65989-97E Dual (Top and Side) Terminal Design.

66000207A International.

Fits '97-later Touring and '09-later Trike models.

66010-97E Dual (Top and Side) Terminal Design.

66000212A International.

Fits '15-later XG, '04-later XL and '08-'12 XR models. Also fits Buell 1125R/CR models.

65958-04C Dual (Top and Side) Terminal Design.

66000208A International.

Fits '02-'06 VRSC and '07 VRSCR models. Also fits Buell XB and Blast models.

65948-00C

66000206A International.

Fits '77-'78 XLCR, '79-'96 XL, '73-'94 electric start FX and FXR, '99-'00 FXR and '84-'90 Softail models. Replaces P/Ns 65991-82A and 65991-75C. Also fits Buell S2/T Thunderbolt™ models.

65991-82B

66000209 International.

Fits '80-'96 FLHR, FLHT and FLT Touring models.

66010-82B

66000210 International.

Fits '91-'96 Dyna and Softail models

65989-90B

66000211 International.

NOTE: Battery dimensions of Harley-Davidson AGM Batteries P/N 65989-97C, 65989-90B and 65991-82B may not allow use of accessory side covers on XL and Dyna models.

CONVENTIONAL BATTERIES* (not shown)

66006-29F 6V.

Fits '64-earlier FL and '63-earlier GE models.

Also available:

H-D® ELECTRICAL CONTACT LUBRICANT (not shown) Ideal for use on multi-pin connectors, bulb bases and battery terminals, this specially formulated Electrical Contact Lubricant offers excellent film strength that is resistant to water (including salt water). Safe for use on tin, nickel, copper, brass, gold and silver contacts, and the formula is compatible with electrical connector plastics and elastomers.

11300004 1 oz (28 g) Tube.

718 GARAGE

Tools

A. ALL-IN-ONE FOLDING TOOL

This kit is the ideal traveling companion. This compact folding tool is equipped to perform the basic on-the-road service functions on most late-model Harley-Davidson® motorcycles. Large comfortable handle with a soft grip adds leverage, and holds the foldaway tools. Tool selection: Torx® bits – T27, T40; Hex Bits – 3/32, 1/4, 3/8; Screwdriver Bits – Phillips, slotted; Open end wrenches (2) – 9/16, 1/2, 10mm. Kit includes nylon pouch with hook-and-loop closure and Bar & Shield logo.

94435-10

Fits '02-later models (except VRSC™, XG RA1250 and RA1250S models).

B. 8-IN-1 SCREWDRIVER

Ideal tool for most of the screws on H-D® products. The unique 8-in-1 design conveniently stores all fittings within handle. Included are #40, 30, 27 and 25 Torx, #2 and 3 Phillips and 2 slotted driver bits. Quality engineered by Snap-On® with lifetime guarantee against breakage.

94669-00

C. COMBINATION AXLE WRENCH

Individual combination front and rear axle wrenches available for your model.

94697-08 .9375 & 36mm.

Fits '08-'17 Dyna®, '08-later Softail® and Touring models.

D. SHOCK ADJUSTMENT SPANNER

The Universal Spanner is small enough to carry in a H-D Tool Kit, and is designed to adjust the spring load on all mechanically adjustable H-D rear shock absorbers.

94448-82B

For use on models with mechanically adjustable H-D rear shock absorbers. Does not fit XG500, XG750, XR, '16-later XL, XL models equipped with Premium Emulsion Shocks P/N 54000076, 54000077 or Dyna models with Premium Emulsion Shocks P/N 54000066.

E. BELT TENSION TESTER TOOL

Use to check tension on secondary belt.

40006-85

F. STAINLESS STEEL TRAYS WITH MAGNETIC BASE

Convenient storage tray with a magnetic base secures small metallic parts during maintenance. Use it horizontally, vertically or upside down. The magnetic base is covered with a protective coating to prevent damage to surface finishes.

94793-01 6 Diameter.



A. ALL-IN-ONE FOLDING TOOL



B. 8-IN-1 SCREWDRIVER



C. COMBINATION AXLE WRENCH



D. SHOCK ADJUSTMENT SPANNER



E. BELT TENSION TESTER TOOL



F. STAINLESS STEEL TRAYS WITH MAGNETIC BASE

GARAGE 719

Tools

G. HARLEY-DAVIDSON® PREMIUM TOOL KIT

This Premium Harley-Davidson® branded Tool Kit features all the tools you need for common maintenance on your motorcycle. The heavy-duty tools are conveniently secured in a hinged carrying case, and lock in place for simple organization. Tools feature large, easy-to-read size indicators, and are stamped with the classic Harley-Davidson script. Lifetime warranty.

64-Piece Kit includes:

- 1 – Quick-Release Ratchet (3/8 Drive)
- 1 – 3 Extension (3/8 Drive)
- 1 – 6 Extension (3/8 Drive)
- 1 – Universal Joint (3/8 Drive)
- 11 – SAE Deep Sockets 3/8 – 1 (3/8 Drive)
- 8 – Metric Deep Sockets 10mm – 17mm (3/8 Drive)
- 1 – Spark Plug Socket 5/8 (3/8 Drive)
- 6 – Hex Sockets 1/8 – 3/8 (3/8 Drive)
- 6 – Torx® Sockets T25-T50 (3/8 Drive)
- 2 – Spinner Handle (1/4 Drive) with Adaptor
- 6 – Bits (Slotted, Phillips, Torx)
- 9 – SAE Combination Wrenches 1/4 – 3/4
- 8 – Metric Combination Wrenches 8mm – 17mm
- 1 – Diagonal Pliers – 7
- 1 – Slip Joint Pliers – 8
- 1 – Needle Nose Pliers – 8

14900033

H. HARLEY-DAVIDSON/SNAP-ON® TOOL KITS

These tool kits were developed specifically for Harley-Davidson by Snap-On® to perform the most functions with the least amount of tools and weight. Provides all the right tools, without compromising quality or damaging your motorcycle's hardware. Lifetime warranty.

H-D®/Snap-On Compact Tool Kit

Designed to provide the most tools in the least amount of space, this tool kit rolls into a compact pouch for easy transport.

94684-00A

For use with '00-later models (except VRSC™, XG and FXR4).

I. HARLEY-DAVIDSON TOOL KIT

This is the ideal carry-along tool kit for your Harley-Davidson motorcycle. The kit was developed to perform most service functions and weigh as little as possible to keep your load light.

94819-02

For use with '86-later XL, '08-'13 XR, '99-'17 Dyna®, and '99-later Softail, Touring, and Trike models.

J. TOOL KIT FOR PAN AMERICA® MODELS

Provides tools necessary for external service and maintenance of your vehicle.

14900127

For use with '21-later Revolution® Max equipped models.



G. HARLEY-DAVIDSON PREMIUM TOOL KIT



H. H-D/SNAP-ON COMPACT TOOL KIT ('00-LATER MODELS SHOWN)



I. HARLEY-DAVIDSON TOOL KIT



J. TOOL KIT FOR PAN AMERICA MODELS

720 GARAGE

Air Filters

A. HARLEY-DAVIDSON® ORIGINAL EQUIPMENT AIR FILTER ELEMENTS

Late-model pleated paper type elements with aluminum back plates.

29400078

Fits '15-'20 XG models (except XG750A).

29331-04

Fits '04-'13 XL models with oval air cleaner assembly.

29400015

Fits '14-later XL models with round air cleaner cover.

29377-08

Fits '08-'12 XR models.

29437-01A

Fits '02-'17 VRSC™ models.

29400042

Fits '99-'06 carbureted Twin Cam equipped models, '01-'15 EFI Softail® (except '08-'11 FLSTSB, '11-later FXS, '12-later FLS and '13-later FXDB) and '02-'07 EFI Touring and Dyna® models.

29633-08

Fits '08-'13 Touring and Trike models.

29400267

Fits '18-later FLFBS, FLHCS, FXBRS and FXFBS and '17-later CVO™ Touring models with Milwaukee-Eight® engine and ventilator air cleaner.

29400248

Fits '18-later Softail® models (except FLFBS, FLHCS, FXBBS, FXBRS, FXFBS and FXLRS).

29400045

Fits '16-'17 Softail (except FLSTFBS) and '14-'16 Touring and Trike models.

29400212

Fits '17-later Touring and Trike models with Milwaukee-Eight engine and wedge-shaped air cleaner.

29191-08

Fits '08-'15 Dyna models with teardrop air cleaner.

29314-08

Fits '13-later FXDB, '12-'15 FLS, '08-'11 FLSTSB and '11-'13 FXS models.

29509-06

Fits '06-'10 FLHTCUSE models.

29462-99

Fits '99-'01 EFI Twin Cam models (except '01 Softail).

29291-95

Fits '95-'99 Evolution® 1340 equipped models with electronic fuel injection (EFI).

29259-91A

Fits '91-'95 Evolution 1340-equipped Dyna, FXR, Softail, and Touring models.

29331-96

Fits '88-'03 Evolution XL models.

29325-95A

Fits '95-'03 Evolution XL and 1340 models. (International models only. See your Dealer.)



A. HARLEY-DAVIDSON ORIGINAL EQUIPMENT AIR FILTER ELEMENTS



A. XR1200 AIR FILTER ELEMENT



A. VRSC AIR FILTER ELEMENT



B. SCREAMIN' EAGLE AIR FILTERS

GARAGE 721

Air Filters

B. SCREAMIN' EAGLE® HIGH-FLO K&N® AIR FILTER ELEMENT

K&N® replacement air filters are engineered to improve airflow for increased horsepower and quicker acceleration. K&N filters provide excellent filtration, and because they are washable and reusable, you can clean the filter whenever conditions demand. Designed as direct replacements for specified fitments.

NOTE: These washable and rechargeable filters use a special coating to help filter fine particles from the incoming air. With time, the oil in the filter will dissipate and the element will begin to turn gray. Clean the surface and renew the original red color with an application of K&N Air Filter Care products.

1. 29400020 High-Flow–Multi-fit. Fits '07-later XL, '99-'07 Dyna®, '00-'15 Softail® and '99-'07 Touring models equipped with High-Flow Air Cleaner Kits. Replacement for P/N 29442-99E.

1. 29400358 High-Flow – Multi-fit. Fits '18-later Softail and '17-later Touring and Trike models equipped with round High-Flow Air Cleaner P/N 29400355 or 29400356.

2. 29400021 High-Flow–Dyna. Fits '08-'17 Dyna models equipped with High-Flow Air Cleaner Kit. Replacement for P/N 29385-08.

3. 29400019 High-Flow–Touring. Fits '16-'17 Softail and '08-'16 Touring and Trike models equipped with High-Flow Air Cleaner Kit. Replacement for P/N 29244-08.

4. 29400247 High-Flow – Wedge. Fits '17-later Touring and Trike models equipped with Wedge High-Flow Air Cleaner Kit P/N 29400245 or 29400246.

5. 29400065 Extreme Billet. Fits '15-later XG, '16-'17 Softail® and '08-'16 Touring and Trike models equipped with Extreme Billet Agitator and Chisel Air Cleaner Kits.

5. 29400118 Extreme Billet & Rail. Fits '07-later XL, '08-'17 Dyna and '08-'15 Softail and models equipped with Extreme Billet Chisel and Agitator or Rail Collection Air Cleaner Kits.

5. 29400359 Extreme. Fits '18-later Softail and '17-later Touring and Trike models equipped with round High-Flow Air Cleaner P/N 29400357.

6. 29400109 Burst Collection. Fits '08-'17 Dyna and Softail models, '08-'16 Touring and Trike models equipped with Burst Collection Air Cleaner Kits.

7. 29400022A Ventilator–Multi-fit. Fits models equipped with Twin-Cam Ventilator and Extreme Billet Ventilator Performance Air Cleaner Kits. Replacement for P/N 29670-09.

8. 29400293 Ventilator. Fits '18-later Softail, '17-later Touring and Trike models equipped with Ventilator Air Cleaner P/N 29400298 or 29400299.

9. 29424-05B Heavy Breather–Multi-fit, Chrome. Fits models equipped with Heavy Breather Kit P/N 29098-09, 29299-08, 29080-09 or 29264-08.

9. 29702-08B Heavy Breather–Touring, Chrome. Fits models equipped with Heavy Breather Kit P/N 29006-09B, 29253-08B, 29000065 or 29400105.

9. 29400297 Heavy Breather–Touring, Black. Fits '16-'17 FXDLS and models equipped with Heavy Breather Kit P/N 29006-09B, 29253-08B, 29000065 or 29400105.

10. 28714-10 Heavy Breather–Compact, Chrome. Fits '08-'16 Touring and Trike models equipped with Compact Heavy Breather Kit P/N 28716-10A.

11. 29400141 Heavy Breather Elite, Chrome. Fits models equipped with Screamin' Eagle® Heavy Breather Elite Performance Air Cleaner Kit P/N 29400172 and 29400173.

11. 27300139 Heavy Breather Elite, Black. Fits Replacement air filter for models equipped with Screamin' Eagle Heavy Breather Elite Performance Air Cleaner Kit P/N 29400285.

12. 29400276 Heavy Breather, Black. Fits '18-later Softail, '17-later Touring and Trike models equipped with Heavy Breather Air Cleaner P/N 29400263 or 29400264.

13. 29400275 Heavy Breather, Chrome. Fits '18-later Softail, '17-later Touring and Trike models equipped with Heavy Breather Air Cleaner P/N 29400263 or 29400264.



B. SCREAMIN' EAGLE HIGH-FLO K&N AIR FILTER ELEMENT



B. SCREAMIN' EAGLE HIGH-FLO K&N AIR FILTER ELEMENT – HEAVY BREATHER



B. SCREAMIN' EAGLE HIGH-FLO K&N AIR FILTER ELEMENT – HEAVY BREATHER

722 GARAGE

Spark Plugs

A. SCREAMIN' EAGLE® PERFORMANCE SPARK PLUGS

Screamin' Eagle® Spark Plugs feature double platinum coating for superior erosion resistance and extended life. The V trimmed ground electrode reduces shrouding of the flame front to promote flame propagation, and the fine wire center electrode enhances startups and ignitability. Screamin' Eagle Plugs feature Ribbed Core Technology (RCT) that provides resistance to fouling, and are designed with Original Equipment-style noise suppression to prevent electrical interference with radios and CB communication equipment. Works great in racing applications where rich air/fuel conditions are required. Unique style with Screamin' Eagle logo. Sold in pairs.

Standard Compression Applications
Designed for modified engines including performance carburetors, high-flow air cleaners, camshafts, exhaust systems and ignition systems in conjunction with stock compression ratios.

31600106 Standard Compression Applications. Fits '99-'17 Twin Cam-equipped models, and '86-later Evolution® Sportster® 883, 1100 and 1200 models.

31600085 Standard Compression Applications. Fits '15-'20 XG models and '17-later Milwaukee-Eight® engine equipped models.

High Compression Applications
These plugs are designed for high-performance applications involving modifications in high-flow air cleaners, camshafts, exhaust, performance heads, ignition components, higher compression ratios above Original Equipment configurations or engines specific for racing applications.

31600105 High Compression Applications. Fits '99-'17 Twin Cam-equipped models. '86-later XL and XR and Evolution® 1340 models equipped with Screamin' Eagle Performance Cylinder Heads.

B. HARLEY-DAVIDSON® GOLD SPARK PLUGS

A special thread and shell coating ensures quick and easy removal from aluminum heads and resists corrosion. A gold palladium insert extends life and improves resistance to corrosion. The tapered tip provides better spark exposure to air/fuel mixture and allows the mixture to flow more easily through gap area for maximum combustibility. Fouling resistance is improved with smaller diameter center electrode wire and insulator tip. Plus, a copper-cored ground electrode runs cooler for extended life.

32365-04 (6R12G) Fits '86-later XL and '99-'17 Twin Cam-equipped models or use in place of No. 6R12.

32367-04 (5R6AG) Fits later '78-'84 Shovelhead and '84-'99 Evolution 1340-equipped models or use in place of Nos. 5R6A and 5RL.

27794-08 (10R12X) Fits '08-'12 XR models.

C. HARLEY-DAVIDSON® ORIGINAL EQUIPMENT SPARK PLUGS

32335-04 (10R12A) Fits '02-'17 VRSC™ models.

31600012 (6R10) Fits '15-'20 XG models and '17-later Milwaukee-Eight engine equipped models.

32342-04 (5R6A) Fits later '78-'84 Shovelhead and '84-'99 Evolution 1340-equipped models.

32362-04A (6R12) Fits '86-later Evolution-equipped XL models and '99-'17 Twin Cam-equipped models.

32338-04 (4R5) Fits '71-'85 Sportster.

32336-04 (4R) Fits '54-'56 KH, '57-'70 XL-900, '71-'85 Iron Sportster and '48-'74 FX and FLH models.

32337-04 (3-4) Fits '48-'74 FLH/FX.

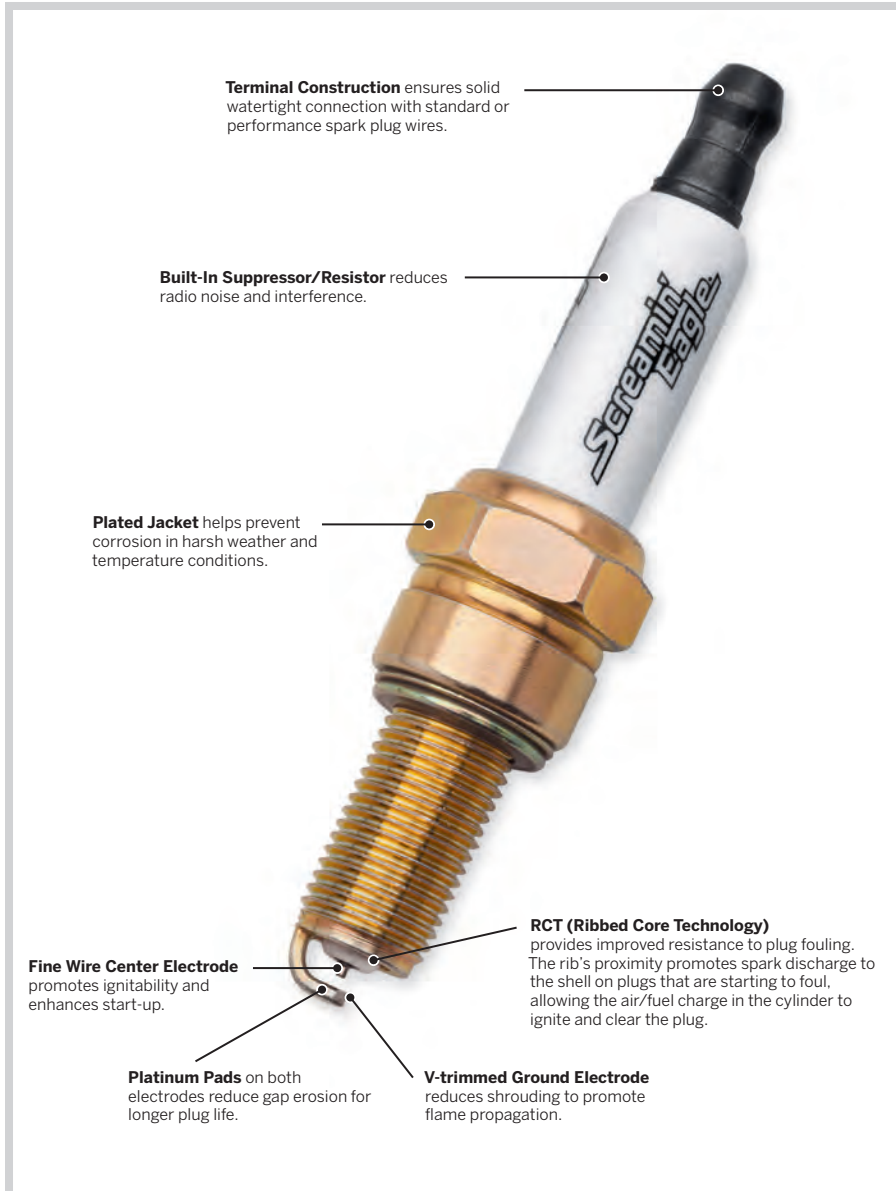

A. SCREAMIN' EAGLE PERFORMANCE SPARK PLUG



B. HARLEY-DAVIDSON GOLD SPARK PLUGS



C. HARLEY-DAVIDSON ORIGINAL EQUIPMENT SPARK PLUGS

GARAGE 723

Brake Pads

D. H-D® ORIGINAL EQUIPMENT BRAKE PADS

Front
41300169 Front. Fits '16-'20 XG models (Left Side on XG750A).

41300196 Front. Fits '17-'20 XG750A models (Right Side).

42897-08 Front. Fits '08-'17 VRSC™ models.

42897-06A Front. Fits '06-'07 VRSC models.

41300004 Front. Fits '14-later XL models.

42831-04A Front. Fits '04-'13 XL models.

42739-08 Front. Fits '08-'13 XR models.

46363-11 Front. Fits '12-'17 Dyna® and '11-'14 Softail® (except Springer™) models.

41300102 Front. Fits '15-later Softail models.

44082-08 Front. Fits '08-'11 Dyna and '08-'10 Softail (except Springer) models.

41854-08 Front. Fits '08-later Touring and '08-'13 and '19-later Trike (includes '20-later FLHTCUTGSE) models.

44063-83D Front. Fits '84-'99 XL, '84-'86 FX, '84-'99 FXR, '91-'99 Dyna, '00-later Springer, '84-'99 Softail and '84-'99 FLHR, FLHT and FLT models.

41300027 Front. Fits '14-'18 Trike models.

Front & Rear
41300072 Front/Rear. Fits '15 XG models

44082-00E Front/Rear. Fits front and rear brakes on '00-'05 VRSC, '00-'03 XL and '00-'07 Dyna, Softail and Touring models (except front brakes on FXSTS and FLSTS Springer). Does not fit '06-'07 rear brakes on FLSTFSE, FXST, FXSTB and FXSTS models.

Rear
41300161 Rear. Fits '16-'20 XG models.

42850-06B Rear. Fits '06-'17 VRSC models.

41300053 Rear. Fits '14-later XL models.

42029-07 Rear. Fits '07-'13 XL models.

42836-04A Rear. Fits '04-'06 XL models.

42310-08 Rear. Fits '08-'13 XR models.

41300197 Rear. Fits '18-later Softail models.

42298-08 Rear. Fits '08-'17 Dyna and Softail models.

44209-87D Rear. Fits later '87-'99 XL, FXR, Softail and '91-'99 Dyna models.

41852-08B Rear. Fits '08-later Touring models. Does not fit Trike models.

43957-86F Rear. Fits '86-'99 FLHR, FLHS, FLHT and FLT models.

41300033 Rear. Fits '14-'18 Trike models.

83911-09B Rear. Fits '09-'13 Trike models.

41300214 Rear. Fits '19-later Trike models.



D. H-D ORIGINAL EQUIPMENT BRAKE PADS

724 GARAGE

Tire Accessories

A. MOTORCYCLE TIRE PRESSURE MONITORING SYSTEM

Proper tire pressure is critical to the operation of your motorcycle. The Harley-Davidson® Tire Pressure Monitoring System (TPMS) takes the hassle out of monitoring your vehicle's front and rear tire pressure manually. The TPMS alerts the rider to low tire pressure as soon as the vehicle is started. While riding, receive low-pressure alerts via your H-D™ Speedo/Tach or via the H-D Connect™ mobile app.

42300124A

Fits '20-later Touring models (except Japan) equipped with Original Equipment or Accessory wheels that accept a TPMS sensor.

B. TIRE PRESSURE GAUGE AND FILL VALVE

Simplify checking the air pressure level and filling the tires on your motorcycle. This Tire Pressure Gauge features an 18 flexible hose and 2-way air chuck with both a 45° fill port and a unique side fill port that provides easy straight-in access to hard-to-reach motorcycle valve stems. The dual-range instant-read gauge measures pressures from 0-60 psi and 0-400 kPa, and is protected from impact and abrasion by a thick rubber collar. Designed to fit an air compressor with a standard 1/4 quick-disconnect coupler, this gauge allows you to check the pressure and fill the tire without removing the chuck from the tire. Just apply the chuck to the valve stem, read the pressure and add air by depressing the comfortable trigger lever. And for checking tire pressure on the road, you can use this tool like any standard tire gauge.

12700096A

C. COMPACT AIR COMPRESSOR WITH LIGHT

Correct tire pressure is crucial to safe operation and long tire life, but checking the pressure, finding a gas station with a working air pump and filling the tire is a chore that many of us ignore. The Compact Air Compressor is designed to simplify this necessary procedure. The compact, lightweight 12V pump is designed for life on the road. The all-in-one pump plugs into your bike's battery charging harness, and features a built-in 0-160 psi pressure gauge and bright LED work light. The 11 air hose and 6' fuse-protected power cord easily reach the front and rear wheels, and are stored in convenient compartments when not in use. The lightweight pump features durable, impact-resistant construction, and is small enough to fit easily in a saddlebag or strap-on luggage. Kit includes pump, valve stem extension and nylon carrying bag.

12700020



A. MOTORCYCLE TIRE PRESSURE MONITORING SYSTEM



B. TIRE PRESSURE GAUGE AND FILL VALVE



C. COMPACT AIR COMPRESSOR WITH LIGHT



D. VALVE STEM EXTENSION



E. COMPACT TIRE GAUGE AND TREAD DEPTH INDICATOR



E. COMPACT TIRE GAUGE AND TREAD DEPTH INDICATOR WITH STAINLESS STEEL LEAD



F. DIGITAL TIRE PRESSURE GAUGE



G. TIRE GAUGE AND TREAD DEPTH INDICATOR WITH EMBOSSED LEATHER POUCH

GARAGE 725

Tire Accessories

D. VALVE STEM EXTENSION

Sometimes there's just not enough space around the tire's valve stem for the gas station air chuck and hose to reach. Brake rotors, sprockets and saddlebags get in the way and keep the air chuck from making an airtight seal. When that happens, this Valve Stem Extension provides easy access. Simply screw the extension in place on the stem, fill the tire to the proper pressure, remove the extension and replace the valve stem cap. Then toss the extension in your saddlebag or tool roll for the next time.

42300009

E. COMPACT TIRE GAUGE AND TREAD DEPTH INDICATOR

Combination dial air pressure and tread depth gauge provides easy access to the valve stem. A durable internal diaphragm provides accurate air pressure readings with a dual range indicator for 0-60 psi and 0-400 kPa readings. The pressure relief valve is activated by a push button to eliminate inner gauge air pressure after use. The integrated tire tread depth gauge features a dual-range color-coded indicator, calibrated in 1/32 (0-14/32) and millimeters (0-11mm), for monitoring tread wear. A protective rubber boot covers the housing to protect the gauge from impact and abrasion.

75008-02A Compact.

75137-98B

Compact with braided stainless steel lead.

F. DIGITAL TIRE PRESSURE GAUGE

Back-lit Digital Tire Pressure Gauge is easy to read at any time of day. Providing accurate pressure readings in 0.50 psi increments up to 60 psi. Scale can be changed to read psi, bar, Kg or kPa pressure with the touch of a button. This versatile gauge features a 12 braided line and 90 degree angle chuck for easy access to valve stems, and a tough rubber jacket to protect the gauge from damage. Batteries are included.

75158-10

G. TIRE GAUGE AND TREAD DEPTH INDICATOR WITH EMBOSSED LEATHER POUCH

Chrome-plated steel gauge housing with Harley-Davidson script and 90 degree air chuck. Dual range indicator for air pressure and tire tread depth readings. Calibrated for 10-50 psi and 0-32/32 tread depth readings. Rotate the indicator shaft 90 degrees in the housing for 70-345 kPa and 0-30mm tread depth readings. Complete with a Bar & Shield logo embossed leather pouch.

75110-98B

DUNLOP® HARLEY-DAVIDSON®

Since 1984, Dunlop® Tires has provided Original Equipment and service replacement tires for Harley-Davidson® motorcycles. Dunlop is recognized as the world-leader in motorcycle tire design, engineering and manufacturing excellence.

DUNLOP® HARLEY-DAVIDSON® TIRE SERIES

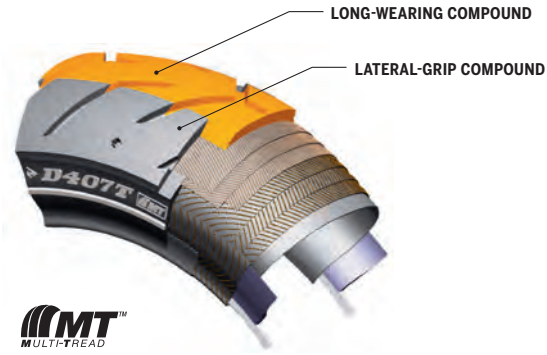

MT MULTI-TREAD
Dunlop D407T and D401T tires feature MT Multi-Tread™ technology that pairs a long-wearing center compound with a high-grip side compound for improved ride, handling and tread life.

Refer to H-D.com/shop for tire fitments or see your Dealer.

DUNLOP · HARLEY-DAVIDSON
D408F TOURING TIRE



DUNLOP® · HARLEY-DAVIDSON® TIRES

D407/D407T/D408 TOURING

The D407/D408 tire is constructed for '09-later FL Touring, select Softail® and specific Custom Vehicle Operations™ (CVO™) models and is available exclusively through Harley-Davidson® Dealers. The FL Touring rear tires feature Dunlop's advanced MT Multi-Tread™ technology.

- Tire features bold Harley-Davidson script on the sidewall.
- MT Multi-Tread rear tire incorporates a tough tread compound in the center that runs cooler to provide stability, excellent traction under braking and long life and to each side is a section of lateral-grip compound that enhances traction at higher lean angles for great grip while cornering.
- Reinforced multi-layer tire carcass gives the tire strength for long life and provides stability at highway speeds and maximum lean angles.
- Bold, angled lateral grooves in the tread pattern evacuate water from the contact patch on wet roads.
- The D407/D408 is available in blackwall, slim white and wide white sidewall styles.
- The D407T is only available in blackwall style.



Blackwall

Slim Whitewall



Blackwall

Slim Whitewall

Wide Whitewall

Engraved Wide Whitewall

D402 TOURING

Built with a three-ply polyester casing with two fiberglass belts, the D402 offers greater load-carrying capacity and stability.

- Computer-optimized tread profile with offset center groove improves rider confidence over rain grooves and steel-grated bridges, while reducing cupping for even wear.
- The D402 is available in blackwall, slim whitewall, wide whitewall and engraved wide whitewall styles.



Blackwall

Wide Whitewall

Blackwall

Blackwall

D401/D401T CRUISER

An advanced tread pattern and specifically formulated compound deliver outstanding grip in wet or dry weather and provide long tire life.

- D401 tires use bias or bias-belted construction and incorporate a computer-optimized tread profile to reduce cupping for even wear.

GT502 PERFORMANCE

GT502 Performance Tires feature an optimized profile, contact patch and compound for superior grip in dry conditions, with solid grip during wet weather riding conditions.

SIGNATURE SERIES

Signature Series Tires are packed with features for responsive handling and confident cornering to tighten the connection between you and the road.

MICHELIN® TIRES

Since 1889, Michelin® has been a leader in the tire industry. From introducing the world's first radial tire in 1946, to being the first to use radial motorcycle tires in race competition, Michelin has demonstrated its dedication to producing some of the world's most innovative tire products. A leader in racing technology, Michelin researches, tests and develops tire solutions in the most demanding form of racing competition. Harley-Davidson® motorcycle riders benefit from that technology, as Michelin transfers track technology into Harley-Davidson motorcycle riding confidence and performance.



MICHELIN SCORCHER® 31 BLACKWALL

Refer to H-D.com/shop for tire fitments or see your Dealer.



MICHELIN® · HARLEY-DAVIDSON® TIRES

MICHELIN® SCORCHER® TIRES

Made exclusively for Harley-Davidson

The Scorchers is the first Michelin®-Harley-Davidson® co-branded tire, with a bold Harley-Davidson script on the sidewall. Featuring an exceptional combination of durability, comfort and handling. The Scorchers 11 and Scorchers 31 are factory-installed on many models, and can be installed as a replacement tire on other specified models.

- **Rear Tire Architecture:**
Provides stability, great handling, plus comfort.
- **3 Polyester Carcass Plies:**
Strong and supple casing for comfort on long rides.
- **2 Aramid Belt Plies:**
Maintains consistent contact patch for a long and even wear life.

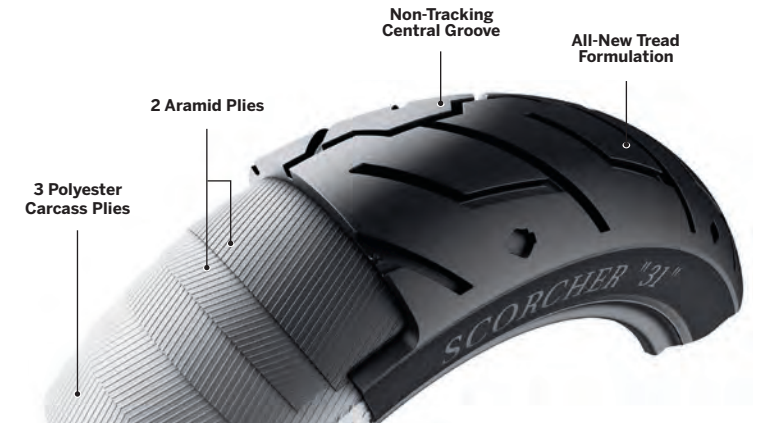

MICHELIN *Scorchers* 31

- **Remarkable Grip:**
Innovative rubber compounds, incorporating know-how derived from Michelin's decades of road-racing experience, provide remarkable grip on both wet and dry roads.
- **Exceptional Comfort and Handling:**
The supple casing design and profile of MICHELIN® Scorchers® 31 tires promote rock-solid handling on winding roads.
- **Long Mileage:**
Michelin carbon black-enriched rubber compounds promote excellent durability without compromising performance.

MICHELIN *Scorchers* 11

- **Outstanding Grip:**
Semi-slick tread pattern maximizes the contact patch for excellent adhesion on dry roads. Optimized tread groove design efficiently evacuates water for dependable wet grip.
- **Excellent Tread Life:**
Derived from Michelin's championship-winning racing tires, newly developed rubber compounds combine durability and high performance.
- **Precise Handling:**
The latest generation of Michelin radial technology allows for easy maneuverability and impressive agility.

